

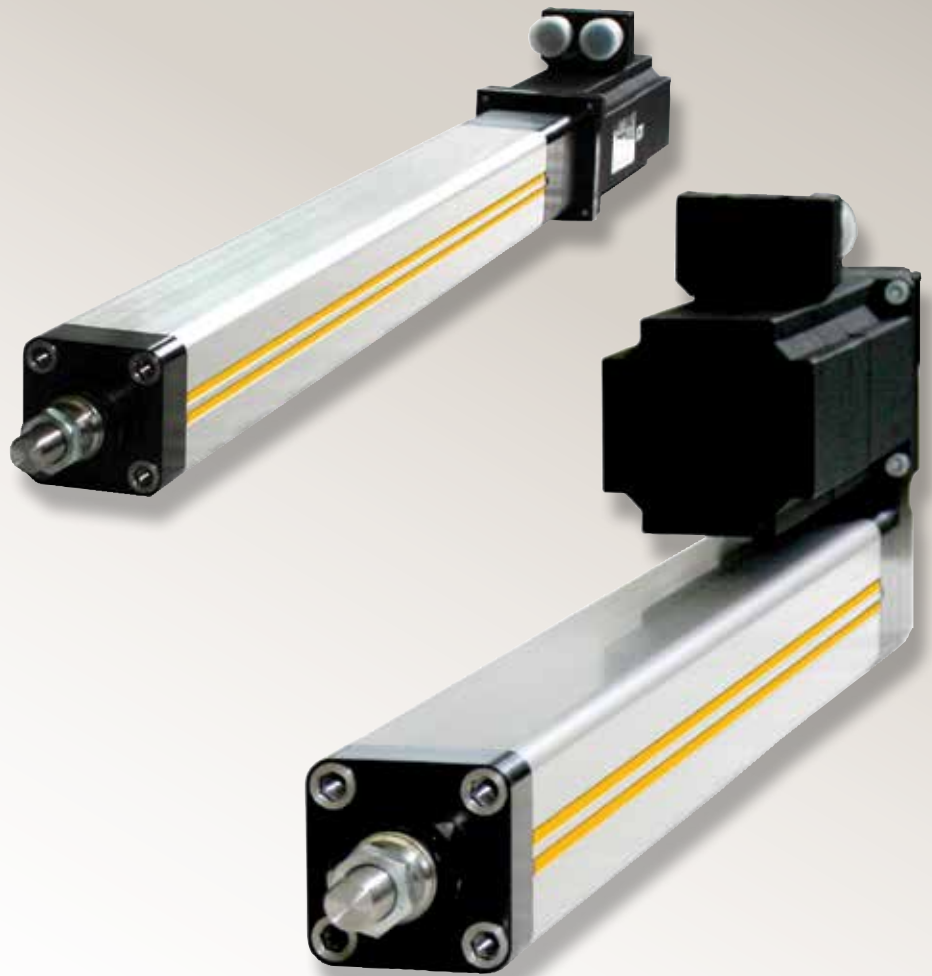

aerospace  
climate control  
electromechanical  
filtration  
fluid & gas handling  
hydraulics  
pneumatics  
process control  
sealing & shielding



# ETH Cylinders

High Force Electric Actuators



ENGINEERING YOUR SUCCESS.

# ETH Series Electric Cylinders

The Parker ETH series is the next generation version of the well known, widely used ET Series.

The ETH design offers unrivaled power density due to larger screw and bearing designs in smaller packages. The result is a product that offers increased force output from a given frame size or increased product life at the same force output.

The ETH is a user-friendly design offered in a diversified range of configurations in order to meet specific application requirements.

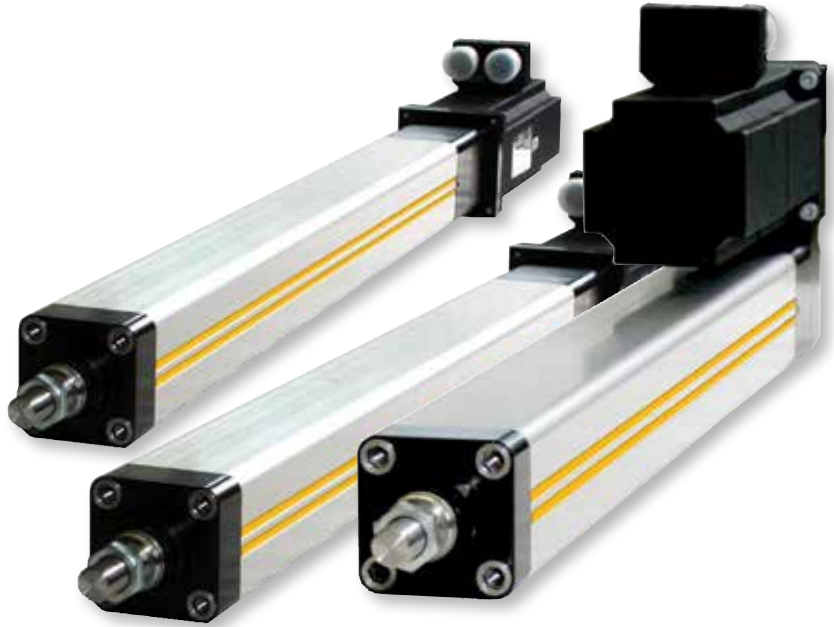

*Available in three profile sizes with both in-line and parallel motor configurations, ETH cylinders provide stroke lengths up to 1600 mm and speeds to 1.7 m/sec.*

## Typical ETH Applications

The ETH electric cylinder closes the gap between electromechanical and hydraulic cylinder performance making it suitable to use in higher force applications where increased

reliability is required in the production process. Taking the costs of the hydraulic system components into consideration you will find that in most cases an electromechanical system such as the ETH electric cylinder offers the more economical solution. Combined with a wide choice of accessories, it offers many possibilities in the following areas of application:

- **Test equipment and laboratory**
- **Valve and flap actuation**
- **Pressing**
- **Packaging machinery**
- **Food and beverage process automation**
- **Material handling and feed systems including: wood and plastic working, vertical actuators for machine tool loading, textile tensioning/gripping, automotive component transport/feeding**

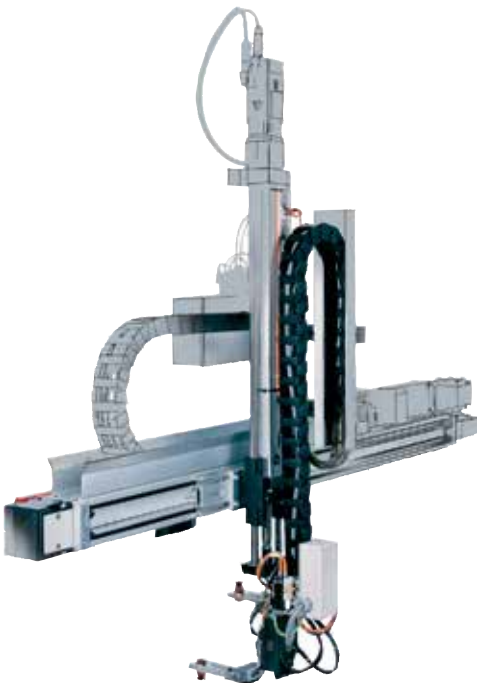

## ETH Solutions for Critical Conditions

If your electric cylinder installation needs to withstand harsh environmental conditions or meet a critical design specification, please contact us.

We offer many non-standard design options not covered in this brochure that will help match the ETH to your specific application requirements, including:

- **Oil-splash lubrication**
- **Customized mountings and rod ends**
- **Mounting of customer motors**
- **Hardened cylinder protection for aggressive environmental conditions**
- **Overlong, polished or chrome-plated thrust rods**
- **Rod bellows**
- **And more...**

# Table of Contents

## Features Overview

4 – 5	ETH Advantages, Performance Characteristics and Design Features
-------	---

## Performance Overview

6	Performance (by Cylinder Size and Screw Lead)
7	ETH032 Speed-Thrust Performance
8	ETH050 Speed-Thrust Performance
9	ETH080 Speed-Thrust Performance

## Motor Mounting Configurations

10 – 13	Inline Motor Mounting Configurations/Dimensions
14 – 17	Parallel Motor Mounting Configurations/Dimensions

## Design Options and Accessories

18 – 21	Cylinder Mounting Options
22 – 25	Rod End Options
26 – 31	Force Sensor, Limit Sensor, Drive/Controller Accessories

## Sizing/Selection – Performance with Select Motors

32	How to use ETH Speed-Thrust Graphs
33 – 34	ETH032 Force-Speed Performance w/Motors (170/340 VDC)
35 – 37	ETH050 Force-Speed Performance w/Motors (170/340/680 VDC)
38	ETH080 Force-Speed Performance w/Motors (340/680 VDC)

## Sizing/Selection – Design Considerations/Calculations

39	Sizing/Selection Design Considerations Overview
40	Stroke, Usable Stroke and Safety Travel
41	Side Loads
42 – 43	Axial Forces
44 – 45	Service Life
46	Relubrication
47	Motor and Gearhead Sizing

## Ordering Information

48 – 49	Order code matrix to build an ETH Cylinder
---------	--

*If you don't find exactly what you are looking for in this brochure, please contact us for information on additional ETH configurations, other suitable Parker products, or to discuss your requirements with an application engineer.*



### Need more information? Visit our Website...

Complete up-to-date technical assistance can be found on the web at [www.parkermotion.com](http://www.parkermotion.com). This includes all the latest information on current products, new product introductions, local assistance and support, plus a comprehensive “Engineering Reference Library” including: complete product catalog data, product selection Wizards, performance charts and graphs, engineering data and calculations, CAD drawings, local service and support directory, on-line purchasing, application stories and videos.

# ETH Series Features Overview

Motor and cylinder design versatility and flexibility make the ETH Series the most user-friendly design.

For applications where overall length requirements restrict the actuator's footprint, the parallel motor configurations are the best solution. The parallel mount configuration is offered with multiple motor options, motor locations and motor orientations. This flexibility gives the user multiple smaller package solutions for solving applications that require increased force density in space-restricted applications.



## New ETH Series Advantages

- **Unrivalled power density – high forces and small frame sizes**
- **Sensor cables can be concealed in the profile**
- **Optimized for safe handling and simple cleaning**
- **Long service life**
- **Reduced maintenance costs thanks to lubricating hole in the cylinder flange**
- **Pneumatic ISO flange norm (DIN ISO 15552:2005-12) conformity**
- **Anti-rotation device integrated**
- **Reduced noise emission**
- **Complete system from a single source: parker offers matching controllers, motors and gearheads for all ETH cylinders**

## Performance Characteristics

For precise motion, positioning, setting and actuating, the electric cylinder offers:

- **High mechanical efficiency up to 90%**
- **Strokes up to 1600 mm**
- **High traction/thrust force up to 25 100 N**
- **Repeatability up to  $\pm 0.03$  mm**
- **Speeds up to 1.7 m/s**
- **Toothed belt drive (for parallel motor mounting)**
- **5 mm to 32 mm screw leads offering fine resolution or high speed options**
- **Three ISO cylinder profile sizes with 30, 40 or 60 mm diameter thrust rods**
- **Predefined standardized motor and gearhead flanges for simplified selection. The motors are available directly from Parker (all from one source).**
- **Three protection classes available:**
  - IP54 with galvanized steel hardware
  - IP54 with stainless steel hardware
  - IP65 epoxy coated cylinder

# Design Features

## ① Support Bearing

The non-motor end of the screw is supported by a hardened polymer bushing which eliminates vibration and minimizes noise for smoother, quieter motion. This also improves precision, increases dynamic performance, and lengthens screw life.

## ② Precision Ballscrew Drive

The ETH drive train features a Class 7 ballscrew (ISO 3408) providing low frictional resistance for smooth motion over the entire speed range. This design also ensures longer product life, excellent efficiency and a lower dB rating. The ballscrew drive provides higher speeds and force capabilities than comparably-sized alternative drive mechanisms.

## ③ Unique Anti-rotation Guide

The ETH features a unique piston rod anti-rotation device. This high quality, maintenance free polymer bushing offers robust guidance that prevents the piston rod from twisting as the rod extends and retracts.

## ④ Screw Support Bearing

A set of double stacked angular contact bearings allows high thrust forces in both extend and retract directions. This design provides high force density and minimizes backlash when changing the direction of motion.

## ⑤ Piston Rod Support Bearing

The piston rod is supported by an extra long rod bushing. This bushing braces the rod in all directions allowing for smooth travel with high side loading capabilities.

## ⑤ Combination Lip and Wiper Seal

The lip and wiper seal keeps contaminants out and lubricating grease in for increased actuator life. For harsh environments, the ETH is available in a robust IP65 version for maximum protection.

## ⑥ Lubrication Port

The ETH comes standard with an integrated lubrication port located in the rear endcap of the cylinder, making scheduled maintenance quick, simple and easy. An optional lubrication bore is available in the middle of the cylinder body for applications where the integrated lubrication port is inaccessible.

## ⑦ Extruded Cylinder Body

The extrusion of the ETH was designed to reduce the number of negative geometry slots and grooves for a cleaner, and more environmentally friendly design. In addition to that, the ETH ships standard with sensor groove covers to help eliminate areas where debris can be trapped.

## ⑧ Home/End of Travel Sensors

The ETH was designed to use Parker's Global Series sensors which mount into the dovetail grooves that run the entire length of the cylinder body. The sensors mount flush to the extrusion body, having no effect on the overall product width. The sensor cables can be concealed with dovetail groove covers giving the actuator a clean, aesthetically appealing appearance. The Global Series sensors are compatible with other Parker products, including pneumatics, helping reduce inventory and spare part complexity.

## ⑨ Permanent magnets

All ETH cylinders are equipped with several permanent magnets integrated into the screw nut which actuate the home/end of travel sensors.

## ⑩ High Force Timing Belt

The parallel mount configuration utilizes a robust toothed timing belt, offering slip-free motion with minimal belt wear. The 1:1 ratio design was designed to transmit higher torques, allowing greater thrust forces at higher speeds. Contact the factory for additional timing belt ratios.

## ⑪ Belt Tensioning

A patent-pending belt tensioning station makes the parallel belt tensioning process quick and easy. This unique design allows for precise and repeatable tensioning, allowing for faster installation time and reduced down time.

## ⑫ Overhung Load Adaptor

For all parallel mounting options which do not include a gearhead, an Overhung Load Adaptor (OLA) is included as part of the actuator assembly. The OLA simplifies the motor mounting process and protects the bearings of the motor from the radial forces induced by the parallel belt tensioning.

## ⑬ Over-stroke Bumpers

Polyurethane over-stroke bumpers are designed in at both ends of the cylinder to protect the internal components from damage as a result of unintended crashes.

# ETH Series Performance Overview

Performance by Cylinder Size and Screw Lead\*

Cylinder Size		ETH032			ETH050			ETH080		
Screw Lead Designation		M05	M10	M16	M05	M10	M20	M05	M10	M32
Screw Lead	mm	5	10	16	5	10	20	5	10	32
Screw diameter	mm	16			20			32		
Available strokes**	mm	50-1000			50-1200			50-1600		
<b>Max. speed at designated stroke:</b>										
50 – 400 mm	mm/s	333	667	1067	333	667	1333	267	533	1707
600 mm		286	540	855	333	666	1318	267	533	1707
800 mm		196	373	592	238	462	917	267	533	1707
1000 mm		146	277	440	177	345	684	264	501	1561
1200 mm		–	–	–	139	270	536	207	394	1233
1400 mm		–	–	–	–	–	–	168	320	1006
1600 mm		–	–	–	–	–	–	140	267	841
Max. Acceleration	m/s <sup>2</sup>	4	8	12	4	8	15	4	8	15
Axial Force – In-line	N	3600	3700	2400	9300	7000	4400	17800	25100	10600
Axial Force – Parallel	n < 100	3600	3280	2050	9300	4920	2460	17800	11620	3630
@ “n” rpm	100 < n < 300	3600	2620	1640	7870	3930	1960	17800	11620	3630
Motor Speed	n > 300	3600	1820	1140	5480	2740	1370	17800	10720	3350
Axial Force – 2500 km Service Life	N	1130	1700	1610	2910	3250	2740	3140	7500	6050
Thrust Force Factor In-line Motor	N/Nm	1131	565	353	1131	565	283	1131	565	177
Transmissible Torque	n < 100	6.5			9.7			22.8		
Parallel Motor @ “n”	100 < n < 300	5.2			7.7			22.8		
rpm Motor Speed	n > 300	3.6			5.4			21.1		
Force Constant Parallel Motor	N/Nm	1018	509	318	1018	509	254	1018	509	159
Max. Torque – No Load	Nm	0.77	0.85	0.94	0.85	1.28	1.70	1.87	2.13	2.38
<b>Weight – with zero stroke</b>										
Basic unit (including cylinder rod)	kg	1.2	1.2	1.3	2.2	2.3	2.5	6.9	7.6	8.7
Cylinder rod only		0.06			0.15			0.59		
<b>Weight of additional length</b>										
Basic unit (including cylinder rod)	kg/m	4.8			8.6			18.7		
Cylinder rod only		0.99			1.85			4.93		
<b>Moments of Inertia</b>										
In-line – without stroke	kgmm <sup>2</sup>	7.1	7.6	12.9	25.3	25.7	33.1	166.2	164.5	252.9
Parallel – without stroke		8.3	8.8	14.1	30.3	30.6	38.0	215.2	213.6	301.9
In-line/Parallel – per meter stroke	kgmm <sup>2</sup> /m	41.3	37.6	41.5	97.7	92.4	106.4	527.7	470.0	585.4
<b>Accuracy: Repeatability (ISO230-2)</b>										
In-line	mm					±0.03				
Parallel						±0.05				
<b>Efficiency – including friction torques</b>										
In-line	%					90				
Parallel						81				
<b>Temperature</b>										
Operating	°C					-10 ... +70				
Ambient						-10 ... +40				
Storage						-20 ... +40				
Humidity	%	0 ... 95 % (non-condensing)								
Elevation (Max.)	m	3000								

\* Technical data based on normal conditions and only for single cylinder and load mode. For compound loads, please verify in accordance with normal physical laws and technical standards whether individual ratings should be reduced. Please contact Parker with any questions.

\*\* Refer to Ordering Information (page 49) for standard strokes available for specified model size and type.

# ETH032 Speed-Thrust

See page 32 for instructions on how to use the data on these graphs

### Maximum Thrust\*:

- Inline motor mount
- Parallel motor with timing belt limitation
- Max thrust at 2540 km of life (see page 45 for details)

### Maximum Speed:

- 1000 mm stroke
- 800 mm stroke
- 600 mm stroke
- Max actuator speed

### Performance Zones:

- Full life region (greater than 2540 km of life)
- Acceptable zone for Inline motor mounts only (motor mount option A or B)
- Intermittent zone (operation will result in reduced life of the actuator and is not acceptable for parallel motor options if above the parallel limitation curve)

\*Maximum thrust assumes a cylinder mounting orientation with a fixed mounting position and a guided load, for limitations on column buckling, please see page 43.

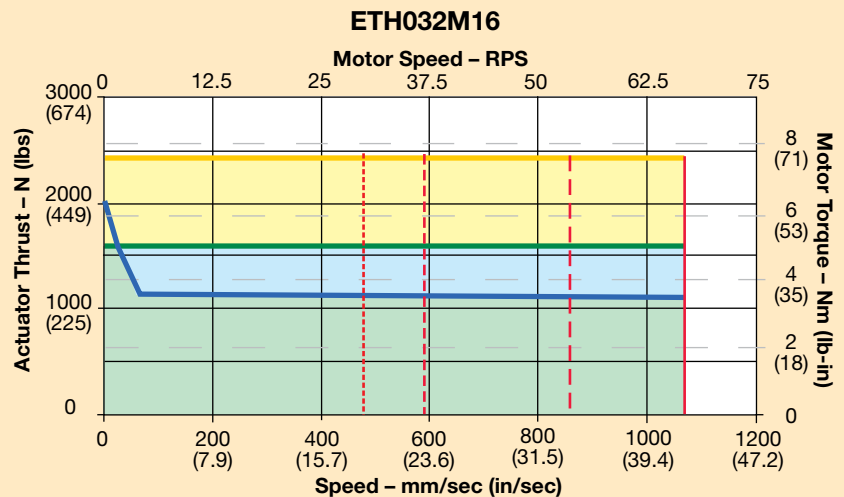
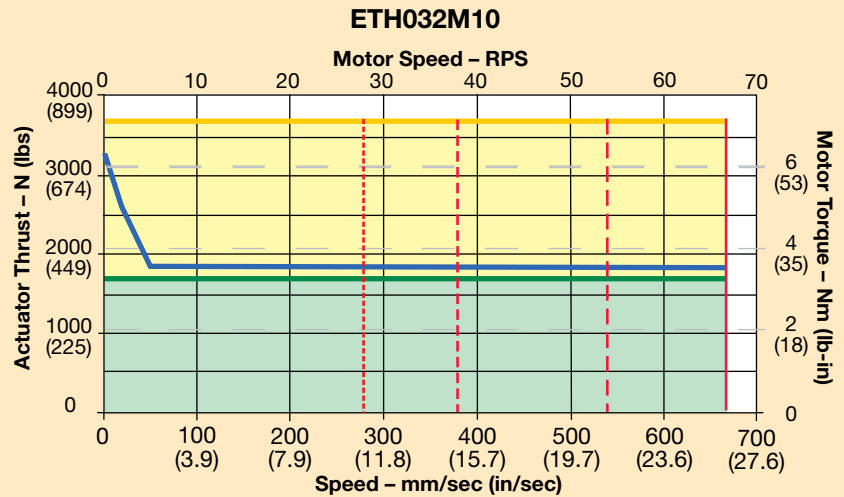
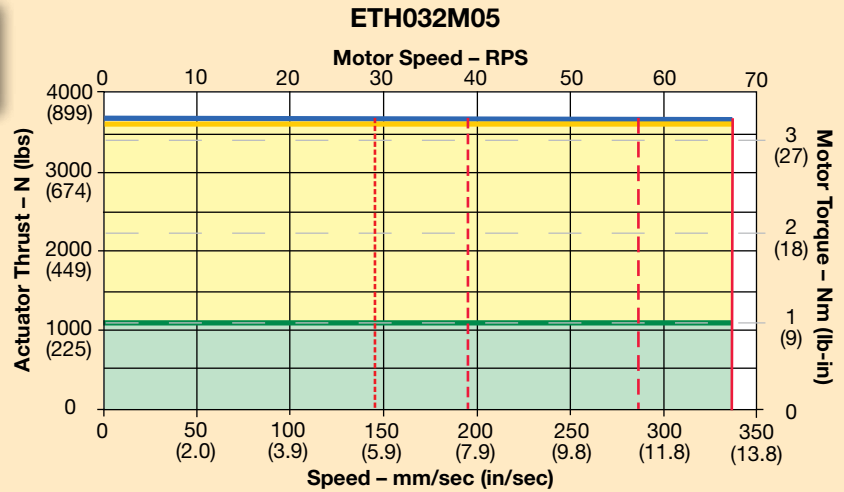

# ETH Series Performance Overview

## ETH050 Speed-Thrust

See page 32 for instructions on how to use the data on these graphs

### Maximum Thrust\*:

- Inline motor mount
- Parallel motor with timing belt limitation
- Max thrust at 2540 km of life (see page 45 for details)

### Maximum Speed:

- - - 1200 mm stroke
- - - 1000 mm stroke
- - - 800 mm stroke
- Max actuator speed

### Performance Zones:

- Full life region (greater than 2540 km of life)
- Acceptable zone for Inline motor mounts only (motor mount option A or B)
- Intermittent zone (operation will result in reduced life of the actuator and is not acceptable for parallel motor options if above the parallel limitation curve)

\*Maximum thrust assumes a cylinder mounting orientation with a fixed mounting position and a guided load, for limitations on column buckling, please see page 43.

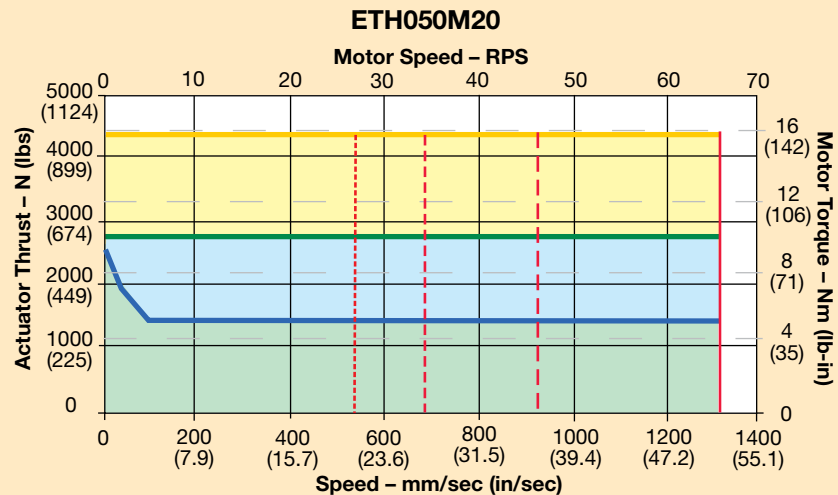
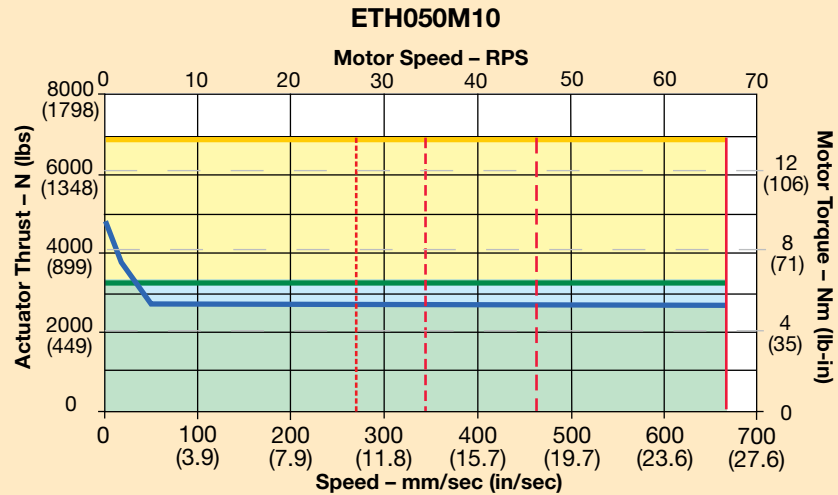
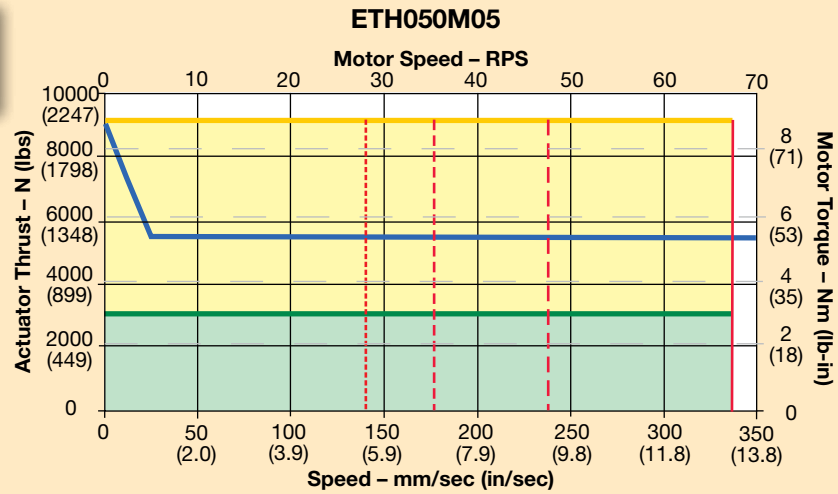



# ETH080 Speed-Thrust

See page 32 for instructions on how to use the data on these graphs

### Maximum Thrust\*:

- Inline motor mount
- Parallel motor with timing belt limitation
- Max thrust at 2540 km of life (see page 45 for details)

### Maximum Speed:

- 1600 mm stroke
- 1400 mm stroke
- 1200 mm stroke
- 1000 mm stroke
- Max actuator speed

### Performance Zones:

- Full life region (greater than 2540 km of life)
- Acceptable zone for Inline motor mounts only (motor mount option A or B)
- Intermittent zone (operation will result in reduced life of the actuator and is not acceptable for parallel motor options if above the parallel limitation curve)

\*Maximum thrust assumes a cylinder mounting orientation with a fixed mounting position and a guided load, for limitations on column buckling, please see page 43.

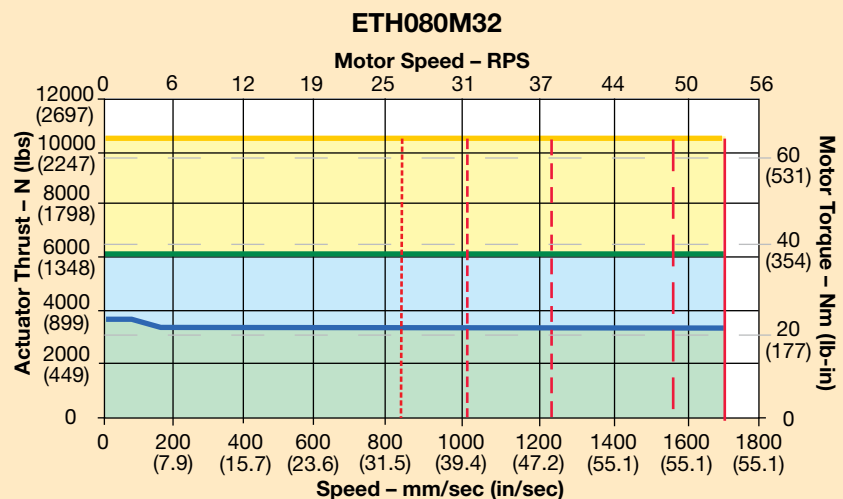
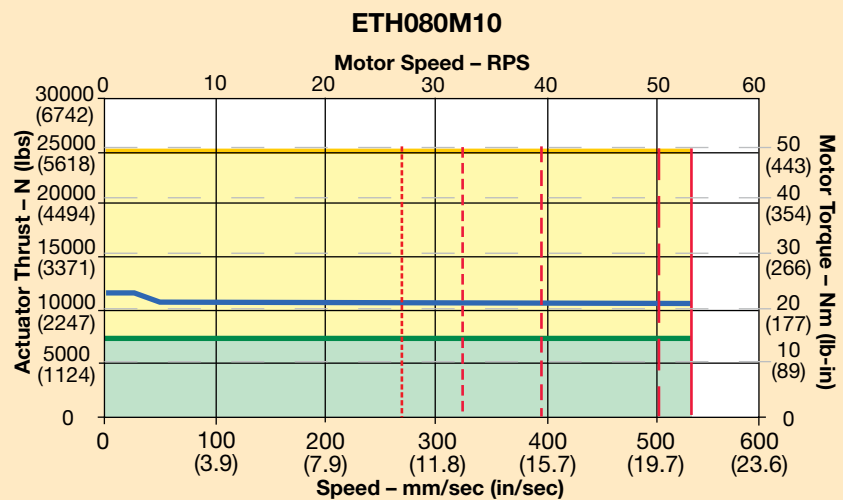
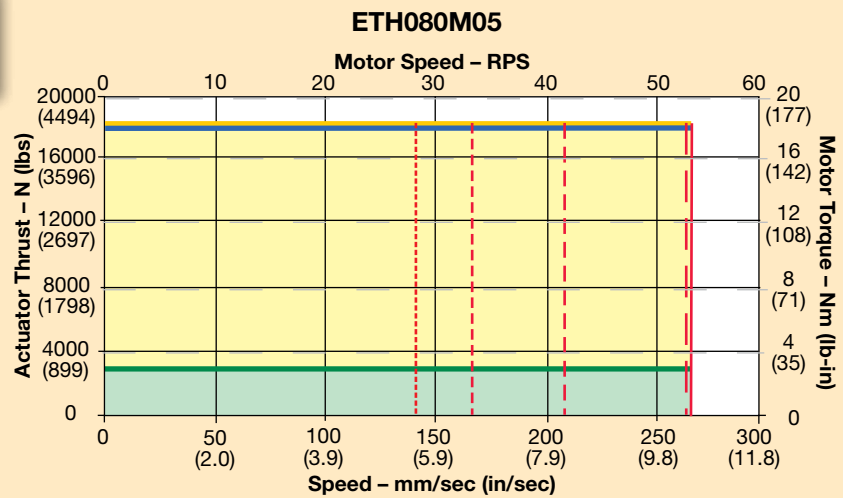

# ETH Motor Mounting Configurations

## Inline Dimensions

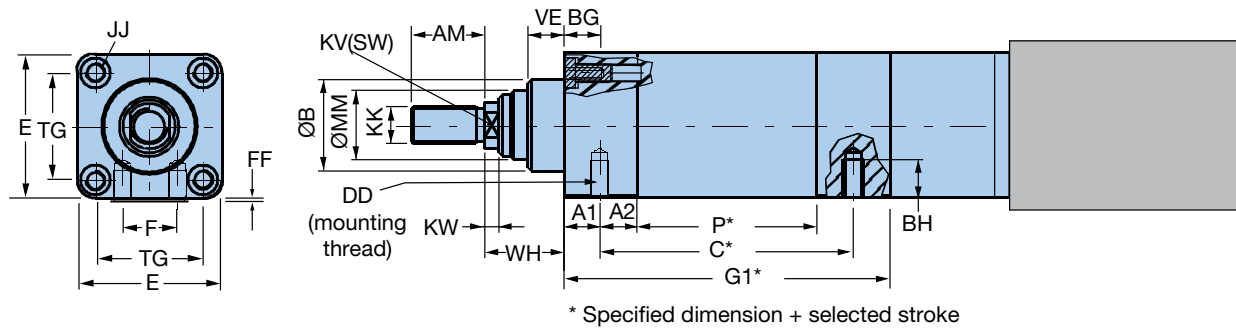

Cylinder Size		ETH032			ETH050			ETH080		
Screw Lead		M05	M10	M16	M05	M10	M20	M05	M10	M32
<b>C</b>	IP54	93.5	103.0	106.5	99.5	105.5	117.5	141.5	159.5	189.5
	IP65	94.5	103.5	107.5	100.5	106.5	118.5	142.5	160.5	190.5
<b>G1</b>	IP54	133.0	142.0	146.0	154.0	160.0	172.0	197.0	215.0	245.0
	IP65	180.5	189.5	193.5	198.5	204.5	216.5	259.5	277.5	307.5
<b>P</b>		66.0	75.0	79.0	67.0	73.0	85.0	89.0	107.0	137.0
<b>A1</b>	IP54		14.0			15.5			21.0	
	IP65		60.0			58.5			82.0	
<b>A2</b>			17.0			18.5			32	
<b>AM</b>			22.0			32.0			40.0	
<b>BG</b>			16.0			25.0			26.0	
<b>BH</b>			9.0			12.7			18.5	
<b>DD</b>			M6x1.0			M8x1.25			M12x1.75	
<b>E</b>			46.5			63.5			95.0	
<b>F</b>			16.0			24.0			30.0	
<b>FF</b>			0.5			0.5			1.0	
<b>JJ</b>			M6x1.0 <sup>(1)</sup>			M8x1.25			M10x1.5	
<b>KK</b>			M10x1.25			M16x1.5			M20x1.5	
<b>KV</b>			10.0			17.0			22.0	
<b>ØMM</b>			22.0			28.0			45.0	
<b>TG</b>			32.5			46.5			72.0	
<b>KW</b>			5.0			6.5			10.0	
<b>VE</b>			12.0			16.0			20.0	
<b>WH</b>			26.0			37.0			46.0	
<b>ØB</b>			30.0			40.0			60.0	

<sup>(1)</sup> Thru holes should have a minimum diameter of 7 mm on any component attached to the front threaded screw holes on bolt pattern TG.

# Inline Mounts with Xpress Motors

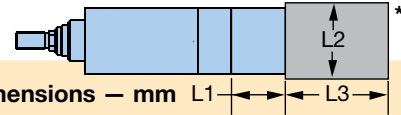

Flange & Coupling to Accept Xpress Motor			Dimensions — mm						
Cylinder Size	Xpress Order Code	Motor (w/Gearhead) Description	Pilot	Bolt Circle	Shaft Ø	Shaft Length	L1	L2	L3
ETH032	XPC	BE233FJ-KPSN	38.10	66.68	9.52	20.8	66.0	58.0	145.0
	XPD	BE233FJ-KPSB	38.10	66.68	9.52	20.8	66.0	58.0	177.0
	XPG	BE344LJ-KPSN	73.03	98.43	12.70	30.2	65.0	85.0	188.0
	XPH	BE344LJ-KPSB	73.03	98.43	12.70	30.2	65.0	85.0	231.0
ETH050	XPC	BE233FJ-KPSN	38.10	66.68	9.52	31.8	65.0	65.0	145.0
	XPD	BE233FJ-KPSB	38.10	66.68	9.52	31.8	65.0	65.0	177.0
	XPG	BE344LJ-KPSN	73.03	98.43	12.70	30.2	63.0	85.0	188.0
	XPH	BE344LJ-KPSB	73.03	98.43	12.70	30.2	63.0	85.0	231.0
	XPL <sup>3</sup>	MPP1003D1E-KPSN	95.00	115.00	19.00	40.0	88.0	98.0	175.0
	XPM <sup>3</sup>	MPP1003D1E-KPSB	95.00	115.00	19.00	40.0	88.0	98.0	223.0
	XPN	MPP1003D1E-KPSN <sup>1</sup>	73.03	98.43	12.70	31.8	63.0	100.0	288.0
	XPP	MPP1003D1E-KPSB <sup>1</sup>	73.03	98.43	12.70	31.8	63.0	100.0	336.0
	XPQ <sup>3</sup>	MPP1003R1E-KPSN	95.00	145.00	19.00	40.0	88.0	98.0	175.0
	XPR <sup>3</sup>	MPP1003R1E-KPSB	95.00	145.00	19.00	40.0	88.0	98.0	223.0
	XPS	MPP1003R1E-KPSN <sup>1</sup>	73.03	98.43	12.70	31.8	63.0	100.0	288.0
	XPT	MPP1003R1E-KPSB <sup>1</sup>	73.03	98.43	12.70	31.8	63.0	100.0	336.0
ETH080	XPG	BE344LJ-KPSN	73.03	98.43	12.70	30.2	92.5	98.0	188.0
	XPH	BE344LJ-KPSB	73.03	98.43	12.70	30.2	92.5	98.0	231.0
	XPL	MPP1003D1E-KPSN	95.00	115.00	19.00	40.0	101.5	98.0	175.0
	XPM	MPP1003D1E-KPSB	95.00	115.00	19.00	40.0	101.5	98.0	223.0
	XPN	MPP1003D1E-KPSN <sup>1</sup>	73.03	98.43	12.70	31.8	92.5	100.0	288.0
	XPP	MPP1003D1E-KPSB <sup>1</sup>	73.03	98.43	12.70	31.8	92.5	100.0	336.0
	XPQ	MPP1003R1E-KPSN	95.00	115.00	19.00	40.0	101.5	98.0	175.0
	XPR	MPP1003R1E-KPSB	95.00	115.00	19.00	40.0	101.5	98.0	223.0
	XPS	MPP1003R1E-NPSN <sup>1</sup>	73.03	98.43	12.70	31.8	92.5	100.0	288.0
	XPT	MPP1003R1E-NPSB <sup>1</sup>	73.03	98.43	12.70	31.8	92.5	100.0	336.0
	XPU	MPP1154B1E-KPSN	110.00	130.00	24.00	50.0	111.5	113.0	203.0
	XPV	MPP1154B1E-KPSB	110.00	130.00	24.00	50.0	111.5	113.0	252.0
	XPW	MPP1154B1E-KPSN <sup>2</sup>	110.00	130.00	24.00	50.0	111.5	115.0	352.5
	XPX	MPP1154B1E-KPSB <sup>2</sup>	110.00	130.00	24.00	50.0	111.5	115.0	401.5
	XPY	MPP1154P1E-KPSN <sup>2</sup>	110.00	130.00	24.00	50.0	111.5	115.0	203.0
	XPZ	MPP1154P1E-KPSB <sup>2</sup>	110.00	130.00	24.00	50.0	111.5	115.0	252.0
XP1	MPP1154P1E-KPSN <sup>2</sup>	110.00	130.00	24.00	50.0	111.5	115.0	352.5	
XP2	MPP1154P1E-KPSB <sup>2</sup>	110.00	130.00	24.00	50.0	111.5	115.0	401.5	

<sup>1</sup> With Parker PV34FE-003 gearhead

<sup>2</sup> With Parker PV115FB-003 gearhead

<sup>3</sup> Requires coupling housing on ETH050 with a square dimension of 80 mm to accommodate a larger coupling.

\* L1 = Length Coupling Housing + Flange  
L2 = Maximum Motor or Gearhead Square Flange  
L3 = Length Motor + Gearhead

# ETH Motor Mounting Configurations

## Inline Mounts for other Parker Motors

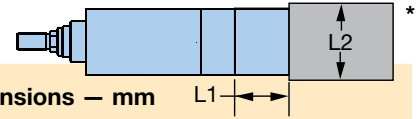

Flange & Coupling to Accept Parker Motor			Dimensions – mm					
Cylinder Size	Kit Order Code	Parker Motor Description	Pilot	Bolt Circle	Shaft Ø	Shaft Length	L1	L2
ETH032	KCB	SM23X	38.10	66.68	9.52	20.8	60.0	58.0
	KBB	BE23X	38.10	66.68	9.52	31.8	66.0	58.0
	KCA	SM16/BE16	20.00	46.69	6.35	25.0	62.0	58.0
	KEA	LV23/HV23	38.10	66.68	6.35	20.8	60.0	58.0
	KBC	BE34X	73.03	98.43	12.70	30.2	65.0	85.0
	KAA	MPP92/MPJ92	80.00	100.00	16.00	40.1	76.0	89.0
	KEB	LV34/HV34	73.03	98.43	12.70	37.1	73.0	85.0
ETH050	KCB	SM23X	38.10	66.68	9.52	20.8	57.5	65.0
	KBB	BE23X	38.10	66.68	9.52	31.8	65.0	65.0
	KBC	BE34X	73.03	98.43	12.70	30.2	63.0	85.0
	KAA	MPP92/MPJ92	80.00	100.00	16.00	40.1	74.0	90.0
	KEB	LV34/HV34	73.03	98.43	12.70	37.1	70.0	85.0
	KAB <sup>1</sup>	MPP100/MPJ100	95.00	115.00	19.00	40.1	88.0	98.0
ETH080	KBB	BE34X	73.03	98.43	12.70	30.2	92.5	98.0
	KAA	MPP92/MPJ92	80.00	100.00	16.00	40.1	101.5	98.0
	KAB	MPP100/MPJ100	95.00	115.00	19.00	40.0	101.5	98.0
	KAC	MPP115/MPJ115	110.00	130.00	24.00	50.0	111.5	113.0

<sup>1</sup> Requires coupling housing on ETH050 with a square dimension of 80 mm to accommodate a larger coupling.

## Inline Mounts for Parker Gearheads

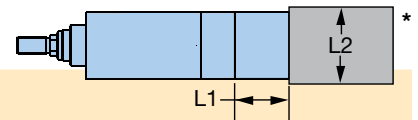

Flange & Coupling to Accept Parker Gearhead			Dimensions – mm					
Cylinder Size	Kit Order Code	Parker Gearhead Description	Pilot	Bolt Circle	Shaft Ø	Shaft Length	L1	L2
ETH032	PAN	PV60FB/PX60	50.00	70.00	16.00	25.0	61.0	62.0
	PCN	PV23FE/PX23	38.10	66.68	9.52	25.4	60.0	58.0
	PDN	PV34FE/PX34	73.03	98.43	12.70	31.8	65.0	85.0
ETH050	PAN	PV60FB/PX60	50.00	70.00	16.00	25.0	60.5	65.0
	PBN <sup>1</sup>	PV90FB/PX90	80.00	100.00	20.00	40.0	93.0	90.0
	PCN	PV23FE/PX23	38.10	66.68	9.52	25.4	65.0	65.0
	PDN	PV34FE/PX34	73.03	98.43	12.70	31.8	63.0	85.0
ETH080	PBN	PV90FB/PX90	80.00	100.00	20.00	40.0	101.5	90.0
	PJN	PV115FB/PX115	95.00	115.00	24.00	50.0	111.5	113.0
	PDN	PV34FE/PX34	73.03	98.43	12.70	31.8	92.5	98.0
	PEN	PV42FE/PX42	55.55	125.70	15.88	38.1	100.0	113.0

<sup>1</sup> Requires coupling housing on ETH050 with a square dimension of 80 mm to accommodate a larger coupling.

\* L1 = Length Coupling Housing + Flange  
L2 = Maximum Motor or Gearhead Square Flange

# Inline Mounts for Non-Standard Motors

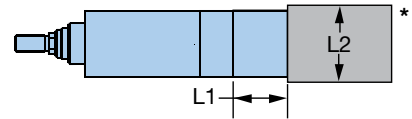

\* L1 = Length Coupling Housing + Flange  
L2 = Maximum Motor or Gearhead Square Flange

## Inline Mounting Compatible Motor Dimensions – mm

Model	Maximum Motor Shaft Ø	
	With Key	Without Key
ETH032	16	16
ETH050	24	24
ETH080	28	28

## Couplers

Order Code	Coupler Size (Motor Shaft Ø)	Compatibility		
		ETH032	ETH050	ETH080
A	No Coupler	•	•	•
B	0.25"	•		
C	0.375"	•	•	
D	0.5"	•	•	
E	0.625"	•	•	
H	6 mm	•	•	
J	8 mm	•		
K	9 mm	•	•	
L	11 mm	•	•	
M	14 mm	•	•	•
N <sup>1</sup>	16 mm	•	•	•
P <sup>1</sup>	19 mm		•	•
Q <sup>1</sup>	20 mm		•	•
R <sup>1</sup>	22 mm		•	•
S <sup>1</sup>	24 mm		•	•

<sup>1</sup> Requires coupling housing on ETH050 with a square dimension of 80 mm to accommodate a larger coupling.

## Ordering Non-Standard Motor Mounts

Use the appropriate order codes from the charts to build the desired “Flange Only” or “Flange and Coupler” Kit Order Code. Note: all non-standard motor mount kits use three character descriptions beginning with an N, followed by a Coupler and a Flange designator.

① ② ③

### Kit Order Code Designators:

N □ □

- ① Non-standard motor mount
- ② Coupler order code
- ③ Flange order code

### Kit Order Code Examples

Kit Order Code Examples	Kit Order Code
No flange, no coupler	NAA
Flange C (for ETH050), no coupler	NAC
Flange C (for ETH050), 0.5" coupler	NDC

## Flanges

Order Code	Dimensions – mm					Compatibility					
	Bolt Circle	Bolt Hole	Pilot Ø	Pilot Depth	Motor Shaft Length	ETH032		ETH050		ETH080	
						L1	L2	L1	L2	L1	L2
A	No Flange					0.0		0.0		0.0	
B	46.00	M3	30.00	3.5	25.0	60.0	58.0	–	–	–	–
C	63.00	M4	40.00	3.5	20.0	60.0	58.0	57.5	65.0	–	–
D	70.00	M5	50.00	3.5	30.0	67.0	65.0	65.5	65.0	–	–
E	75.00	M5	60.00	3.5	23.0	60.0	70.0	59.0	70.0	–	–
F	75.00	M5	60.00	3.5	30.0	66.0	70.0	59.0	70.0	–	–
G	90.00	M6	70.00	3.5	40.0	–	–	84.0	96.0	92.5	96.0
H	95.00	M5	50.00	3.5	30.0	76.0	82.0	65.5	82.0	–	–
J	100.00	M6	80.00	3.5	40.0	76.0	89.0	84.0	96.0	94.5	96.0
K	115.00	M8	95.00	3.5	40.0	–	–	84.0	100.0	94.5	100.0
L	130.00	M8	110.00	3.5	50.0	–	–	–	–	104.5	115.0
M	130.00	M8	95.00	3.5	50.0	–	–	–	–	101.5	115.0

# ETH Motor Mounting Configurations

## Parallel Dimensions

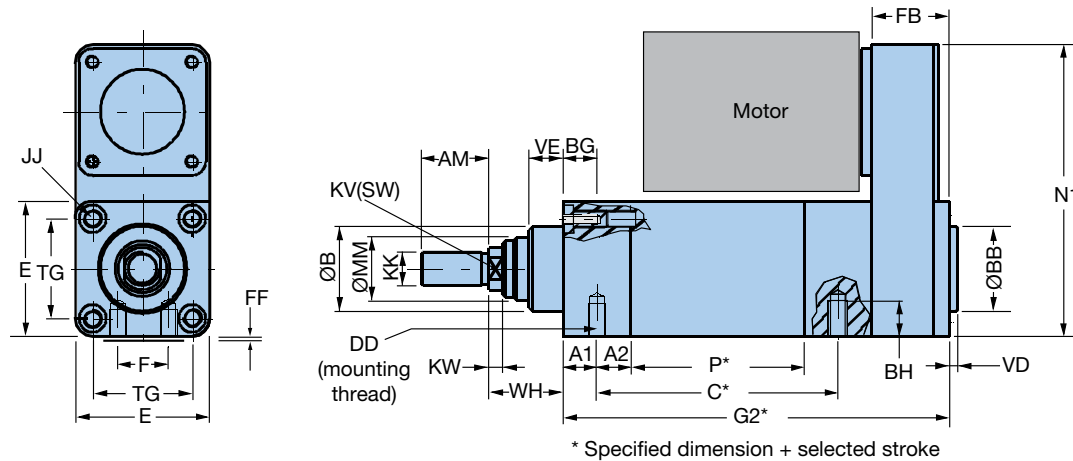

Cylinder Size		ETH032			ETH050			ETH080		
<b>Screw Lead</b>		<b>M05</b>	<b>M10</b>	<b>M16</b>	<b>M05</b>	<b>M10</b>	<b>M20</b>	<b>M05</b>	<b>M10</b>	<b>M32</b>
<b>C</b>	IP54	93.5	103.0	106.5	99.5	105.5	117.5	141.5	159.5	189.5
	IP65	94.5	103.5	107.5	100.5	106.5	118.5	142.5	160.5	190.5
<b>G2</b>	IP54	180.5	189.5	193.5	194.0	200.0	212.0	257.0	275.0	305.0
	IP65	228.5	237.5	241.5	239.0	245.0	257.0	320.0	338.0	368.0
<b>P</b>		66.0	75.0	79.0	67.0	73.0	85.0	89.0	107.0	137.0
<b>A1</b>	IP54		14.0			15.5			21.0	
	IP65		60.0			58.5			82.0	
<b>A2</b>			17.0			18.5			32	
<b>AM</b>			22.0			32.0			40.0	
<b>BG</b>			16.0			25.0			26.0	
<b>BH</b>			9.0			12.7			18.5	
<b>DD</b>			M6x1.0			M8x1.25			M12x1.75	
<b>E</b>			46.5			63.5			95.0	
<b>F</b>			16.0			24.0			30.0	
<b>FF</b>			0.5			0.5			1.0	
<b>JJ</b>			M6x1.0 <sup>(1)</sup>			M8x1.25			M10x1.5	
<b>KK</b>			M10x1.25			M16x1.5			M20x1.5	
<b>KV</b>			10.0			17.0			22.0	
<b>ØMM</b>			22.0			28.0			45.0	
<b>TG</b>			32.5			46.5			72.0	
<b>KW</b>			5.0			6.5			10.0	
<b>N1</b>			126.0			160.0			233.5	
<b>FB</b>	IP54		47.5			40.0			60.0	
	IP65		48.0			40.5			60.5	
<b>VD</b>			4.0			4.0			4.0	
<b>ØBB</b>			30.0			40.0			45.0	
<b>VE</b>			12.0			16.0			20.0	
<b>WH</b>			26.0			37.0			46.0	
<b>ØB</b>			30.0			40.0			60.0	

<sup>(1)</sup> Thru holes should have a minimum diameter of 7 mm on any component attached to the front threaded screw holes on bolt pattern TG.

# Parallel Mounts with Xpress Motors

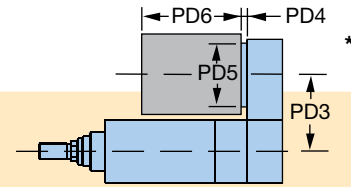

Flange & Coupling to Accept Xpress Motor			Dimensions — mm							
Cylinder Size	Xpress Order Code	Motor (w/Gearhead) Description	Bolt		Shaft		PD3	PD4	PD5	PD6
			Pilot	Circle	Shaft Ø	Length				
ETH032	XPC	BE233FJ-KPSN	38.10	66.68	9.52	31.8	67.5	78.5	62.0	145.0
	XPD	BE233FJ-KPSB	38.10	66.68	9.52	31.8	67.5	78.5	62.0	177.0
	XPG	BE344LJ-KPSN	73.03	98.43	12.70	30.2	67.5	78.5	80.0	188.0
	XPH	BE344LJ-KPSB	73.03	98.43	12.70	30.2	67.5	78.5	80.0	231.0
ETH050	XPC	BE233FJ-KPSN	38.10	66.68	9.52	31.8	87.5	78.5	62.0	145.0
	XPD	BE233FJ-KPSB	38.10	66.68	9.52	31.8	87.5	78.5	62.0	177.0
	XPG	BE344LJ-KPSN	73.03	98.43	12.70	30.2	87.5	84.0	90.0	188.0
	XPH	BE344LJ-KPSB	73.03	98.43	12.70	30.2	87.5	84.0	90.0	231.0
	XPL	MPP1003D1E-KPSN	95.00	115	19.00	40.0	87.5	92.5	100.0	175.0
	XPM	MPP1003D1E-KPSB	95.00	115	19.00	40.0	87.5	92.5	100.0	223.0
	XPN	MPP1003D1E-KPSN *	73.03	98.43	12.70	31.8	87.5	128.0	100.0	175.0
	XPP	MPP1003D1E-KPSB *	73.03	98.43	12.70	31.8	87.5	128.0	100.0	223.0
	XPQ	MPP1003R1E-KPSN	73.03	98.43	12.70	31.8	87.5	92.5	100.0	175.0
	XPR	MPP1003R1E-KPSB	73.03	98.43	12.70	31.8	87.5	92.5	100.0	223.0
	XPS	MPP1003R1E-KPSN *	73.03	98.43	12.70	31.8	87.5	128.0	100.0	175.0
	XPT	MPP1003R1E-KPSB *	73.03	98.43	12.70	31.8	87.5	128.0	100.0	223.0
ETH080	XPG	BE344LJ-KPSN	73.03	98.43	12.70	30.2	130.0	84.0	90.0	188.0
	XPH	BE344LJ-KPSB	73.03	98.43	12.70	30.2	130.0	84.0	90.0	231.0
	XPL	MPP1003D1E-KPSN	95.00	115.00	19.00	40.0	130.0	95.3	100.0	175.0
	XPM	MPP1003D1E-KPSB	95.00	115.00	19.00	40.0	130.0	95.3	100.0	223.0
	XPN	MPP1003D1E-KPSN **	73.03	98.43	12.70	31.8	130.0	137.0	100.0	175.0
	XPP	MPP1003D1E-KPSB **	73.03	98.43	12.70	31.8	130.0	137.0	100.0	223.0
	XPQ	MPP1003R1E-KPSN	95.00	115.00	19.00	40.0	130.0	95.3	100.0	175.0
	XPR	MPP1003R1E-KPSB	95.00	115.00	19.00	40.0	130.0	95.3	100.0	223.0
	XPS	MPP1003R1E-KPSN **	73.03	98.43	12.70	31.8	130.0	137.0	100.0	175.0
	XPT	MPP1003R1E-KPSB **	73.03	98.43	12.70	31.8	130.0	137.0	100.0	223.0
	XPU	MPP1154B1E-KPSN	110.00	130.00	24.00	50.0	130.0	127.0	115.0	203.0
	XPV	MPP1154B1E-KPSB	110.00	130.00	24.00	50.0	130.0	127.0	115.0	252.0
	XPW	MPP1154B1E-KPSN ***	110.00	130.00	24.00	50.0	130.0	170.0	115.0	203.0
	XPX	MPP1154B1E-KPSB ***	110.00	130.00	24.00	50.0	130.0	170.0	115.0	252.0
	XPY	MPP1154P1E-KPSN	110.00	130.00	24.00	50.0	130.0	127.0	115.0	203.0
	XPZ	MPP1154P1E-KPSB	110.00	130.00	24.00	50.0	130.0	127.0	115.0	252.0
XP1	MPP1154P1E-KPSN ***	110.00	130.00	24.00	50.0	130.0	170.0	115.0	203.0	
XP2	MPP1154P1E-KPSB ***	110.00	130.00	24.00	50.0	130.0	170.0	115.0	252.0	

\* With Parker PV34FE-003 gearhead

\*\* With Parker PV90FB-003 gearhead

\*\*\* With Parker PV115FB-003 gearhead

\* PD4 = Flange + Gearhead/overhung load adaptor  
 PD5 = Flange + Gearhead/overhung load adaptor  
 PD6 = Motor only

# ETH Motor Mounting Configurations

## Parallel Mounts for other Parker Motors

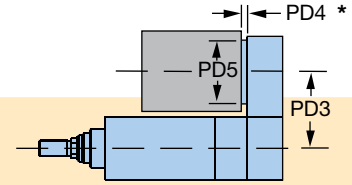

Flange & Coupling to Accept Parker Motor			Dimensions – mm						
Cylinder Size	Kit Order Code	Parker Motor Description							
			Pilot	Bolt Circle	Shaft Ø	Shaft Length	PD3	PD4	PD5
ETH032	KCB	SM23X	38.10	66.68	9.52	20.8	67.5	72.5	62.0
	KBB	BE23X	38.10	66.68	9.52	31.8	67.5	78.5	62.0
	KCA	SM16/BE16	20.00	46.69	6.35	25.0	67.5	72.5	62.0
	KEA	LV23/HV23	38.10	66.68	6.35	20.8	67.5	72.5	62.0
	KBC	BE34X	73.03	98.43	12.70	30.2	67.5	78.5	80.0
	KEB	LV34/HV34	73.03	98.43	12.70	37.1	67.5	78.5	80.0
ETH050	KCB	SM23X	38.10	66.68	9.52	20.8	87.5	72.5	62.0
	KBB	BE23X	38.10	66.68	9.52	31.8	87.5	78.5	62.0
	KBC	BE34X	73.03	98.43	12.70	30.2	87.5	84.0	90.0
	KAA	MPP92/MPJ92	80.00	100	16.00	40.1	87.5	92.5	90.0
	KEB	LV34/HV34	73.03	98.43	12.70	37.1	87.5	92.5	90.0
	KAB	MPP100/MPJ100	95.00	115	19.00	40.1	87.5	92.5	100.0
ETH080	KBB	BE34X	73.03	98.43	12.70	30.2	130.0	87.0	90.0
	KAA	MPP92/MPJ92	80.00	100.00	16.00	40.1	130.0	96.0	90.0
	KAB	MPP100/MPJ100	95.00	115.00	19.00	40.0	130.0	96.0	100.0
	KAC	MPP115/MPJ115	110.00	130.00	24.00	50.0	130.0	127.0	115.0

## Parallel Mounts for Parker Gearheads

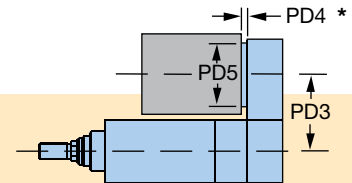

Flange & Coupling to Accept Parker Motor			Dimensions – mm						
Cylinder Size	Kit Order Code	Parker Gearhead Description							
			Pilot	Bolt Circle	Shaft Ø	Shaft Length	PD3	PD4	PD5
ETH032	PAN	PV60FB/PX60	50.00	70.00	16.00	25.0	67.5	12.0	62.0
ETH050	PAN	PV60FB/PX60	50.00	70.00	16.00	25.0	87.5	12.0	63.5
	PDN	PV34FE/PX34	73.03	98.43	12.70	31.8	87.5	15.0	90.0
ETH080	PBN	PV90FB/PX90	80.00	100.00	20.00	40.0	130.0	18.0	90.0
	PJN	PV115FB/PX115	110.00	130.00	24.00	50.0	130.0	20.0	115.0

\* PD4 = Flange + Gearhead/overhung load adaptor  
 PD5 = Flange + Gearhead/overhung load adaptor  
 PD6 = Motor only



# Parallel Mounts for Non-Standard Motors

## Parallel Mounting Compatible Motor Dimensions - mm

Cylinder Size	Max. Shaft Ø		Max. Square Motor Flange
	With Key	Without Key	
ETH032	—	14 (w/PV60 gearhead)	85
ETH050	—	20 (w/PV90 gearhead) or	100
ETH080	—	24 (w/PV115 gearhead)	150

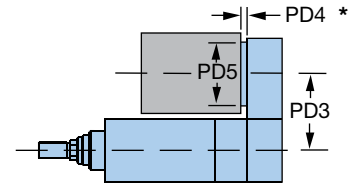

\* PD4 = Flange + Gearhead/overhang load adaptor  
 PD5 = Flange + Gearhead/overhang load adaptor  
 PD6 = Motor only

## Sleeves

Order Code	Sleeve Size (Motor Shaft Ø)	Compatibility		
		ETH032	ETH050	ETH080
A	No Coupler	•	•	•
B	0.25"	•		
C	0.375"	•	•	
D	0.5"	•	•	
E	0.625"	•	•	
H	6 mm	•	•	
J	8 mm	•		
K	9 mm	•	•	
L	11 mm	•	•	
M	14 mm	•	•	•
N	16 mm		•	•
P	19 mm		•	•
Q	20 mm		•	•
R	22 mm			•
S	24 mm			•

## Ordering Non-Standard Motor Mounts

Use the appropriate order codes from the charts to build the desired "Flange Only" or "Flange and Sleeve" Kit Order Code. Note: all non-standard motor mount kits use three character descriptions beginning with an N, followed by a Sleeve and a Flange designator.

① ② ③

Kit Order Code Designators: N

- ① Non-standard motor mount
- ② Sleeves order code
- ③ Flange order code

Kit Order Code Examples

Kit Order Code Examples	Kit Order Code
No flange, no sleeve	NAA
Flange C (for ETH050), no sleeve	NAC
Flange C (for ETH050), 0.5" sleeve	NDC

## Flanges

Order Code	Dimensions – mm					Compatibility								
	Bolt Circle	Bolt Hole	Pilot Ø	Pilot Depth	Motor Shaft Length	ETH032			ETH050			ETH080		
						PD3	PD4	PD5	PD3	PD4	PD5	PD3	PD4	PD5
A	No Flange					0.0			0.0			0.0		
B	46.00	M3	30.00	3.5	25.0	67.5	72.5	62.0	—	—	—	—	—	—
C	63.00	M4	40.00	3.5	20.0	67.5	72.5	62.0	87.5	72.5	60.0	—	—	—
D	70.00	M5	50.00	3.5	30.0	67.5	78.5	62.0	87.5	78.5	63.5	—	—	—
E	75.00	M5	60.00	3.5	23.0	67.5	78.5	62.0	87.5	84.0	90.0	—	—	—
F	75.00	M5	60.00	3.5	30.0	67.5	72.5	62.0	87.5	84.0	90.0	—	—	—
G	90.00	M6	70.00	3.5	40.0	—	—	—	—	—	—	130.0	96.0	90.0
H	95.00	M5	50.00	3.5	30.0	67.5	78.5	82.0	87.5	84.0	90.0	—	—	—
J	100.00	M6	80.00	3.5	40.0	—	—	—	87.5	92.5	90.0	130.0	96.0	90.0
K	115.00	M8	95.00	3.5	40.0	—	—	—	87.5	92.5	100.0	130.0	96.0	100.0
L	130.00	M8	110.00	3.5	50.0	—	—	—	—	—	—	130.0	127.0	115.0
M	130.00	M8	95.00	3.5	50.0	—	—	—	—	—	—	130.0	116.0	115.0

# ETH Cylinder Mounting Options

Order Code

## B Foot Mount

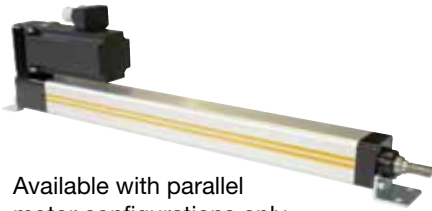

Available with parallel motor configurations only

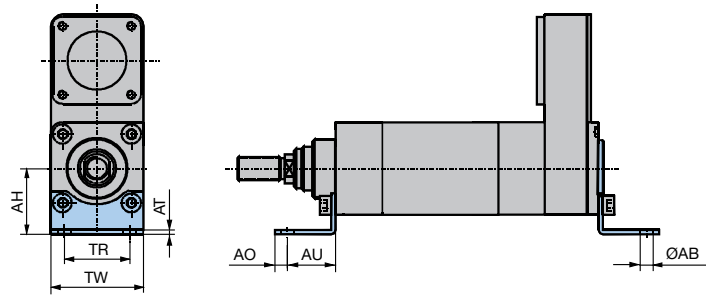

Size	Part Number* (1 piece each)		Dimensions – mm						
	Rear Bracket	Front Bracket	AH	AT	TR	ØAB (H14)	AO	AU	TW
ETH032	0111.065		32	4	32	7.0	8	24	48
ETH050	0121.065		45	4	45	9.0	12	32	65
ETH080	0131.065-01	0131.065-02	63	6	63	13.5	15	41	95

\* Use order code when ordering cylinder; use part number for ordering spare replacement parts

## C Rear Clevis Mount



Available with parallel motor configurations only

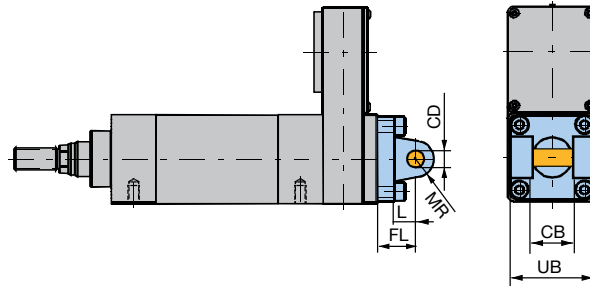

Size	Part Number*	Dimensions – mm					
		UB (h13)	CB (H14)	ØCD (H9)	MR	L	FL ±0.2
ETH032	0112.031	46.5	26	10	9.5	13	22
ETH050	0122.031	63.5	32	12	12.5	16	27
ETH080	0132.031	95	50	16	17.5	22	36

\* Use order code when ordering cylinder; use part number for ordering spare replacement parts

## Optional Bearing Block



Mating mount bracket to rear clevis. Please order separately.

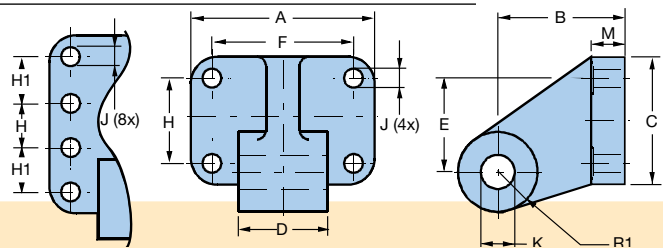

Cylinder Size	Part Number	Dimensions – mm											
		A	B	C	D	E	F	H	H1	ØJ (H13)	ØK (H9)	M	R1
ETH032	0112.039	55	32	55	26	43.0	38	38	—	9	10	8	11.0
ETH050	0122.039	70	45	70	32	52.5	48	48	—	11	12	12	13.0
ETH080	0132.039	95	63	150	50	130.5	72	45	40	13	16	16	16.5

## D Center Trunnion Mount

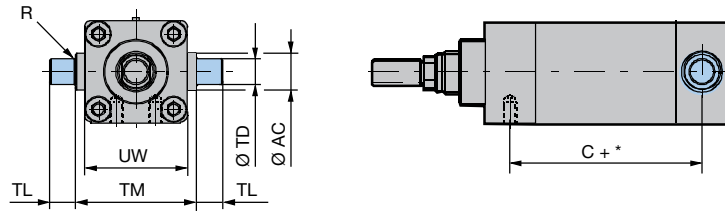

Factory installed. Cannot be ordered separately.

Cylinder Size	Dimensions – mm					
	UW	ØTD**	R	TL	TM	ØAC
ETH032	46.5	12	1	12	50	18
ETH050	63.5	16	1	16	75	25
ETH080	95.3	25	2	25	110	35

\* Dimension C+ = Dimension + length of desired stroke (see page 40 for calculating stroke)

\*\* : ØTD in accordance with ISO tolerance zone h8

Note: For relubrication option "1" (Integrated lubrication port) please see mounting method with option "D" center trunnion always on 6 o'clock!

## E Rear Eye Mount

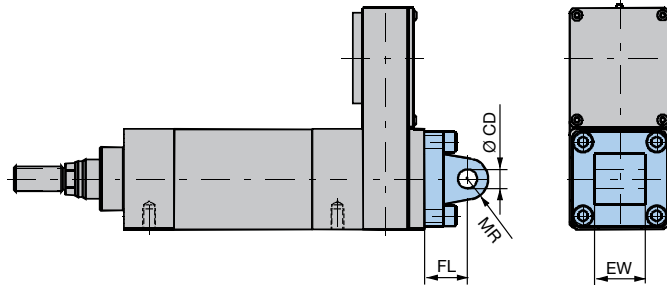

Available with parallel motor configurations only

Cylinder Size	Part Number*	Dimensions – mm			
		EW	ØCD	MR (H9)	FL ±0.2
ETH032	0112.033	26	10	11	22
ETH050	0122.033	32	12	13	27
ETH080	0132.033	50	16	17	36

\* Use order code when ordering cylinder; use part number for ordering spare replacement parts

## F Tapped Bottom Holes (Standard)

Mounting with 4 threaded holes on bottom of the cylinder.

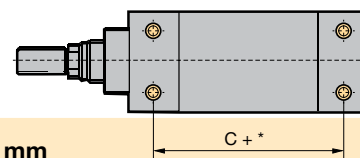

Cylinder Size	Dimension C + – mm									
	ETH032			ETH050			ETH080			
Screw Lead	M05	M10	M16	M05	M10	M20	M05	M10	M32	
C + *	IP54	93.5	103.0	106.5	99.5	105.5	117.5	141.5	159.5	189.5
	IP65	94.5	103.5	107.5	100.5	106.5	118.5	142.5	160.5	190.5

\* Dimension C+ = Dimension + length of desired stroke (see page 40 for calculating stroke)

# ETH Cylinder Mounting Options

Order Code

## G Side Flange Mount

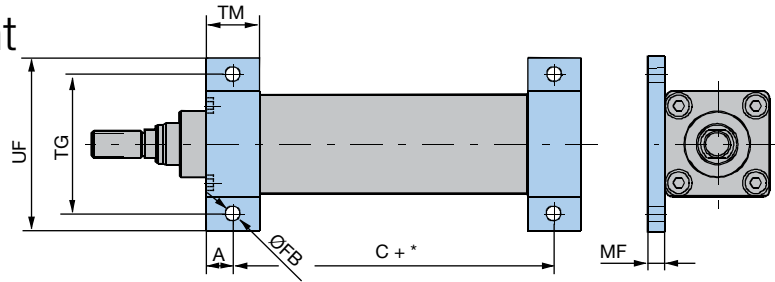

Flanges are stainless steel

Cylinder Size	Part Number**	Dimensions – mm					
		TG	UF	ØFB	TM	MF	A
ETH032	1440.079	62	78	6.6	25	8	12.5
ETH050	1441.093	84	104	9.0	30	10	15.0
ETH080	0131.078	120	144	13.5	40	12	20.0

\* Dimension C+ = Dimension + length of desired stroke (see page 40 for calculating stroke)

\*\* Use order code when ordering cylinder; use part number for ordering spare replacement parts (one piece per part number)

## H Rear Plate Mount

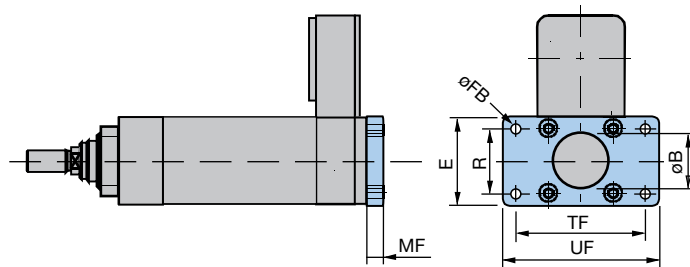

Plate is stainless steel

Cylinder Size	Part Number*	Dimensions – mm						
		MF	UF	TF	E	R	ØFB	ØB
ETH032	0111.064	10	80	64	48	32	7	30
ETH050	0121.064	12	110	90	65	45	9	40
ETH080	0131.064-01	16	150	126	95	63	12	45

\* Use order code when ordering cylinder; use part number for ordering spare replacement parts (one piece per part number)

## J Front Plate Mount

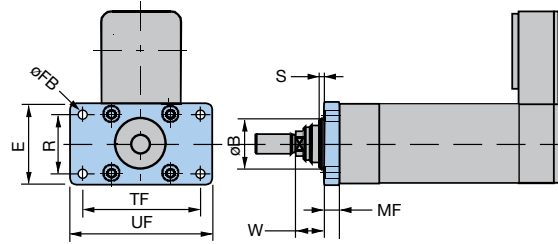
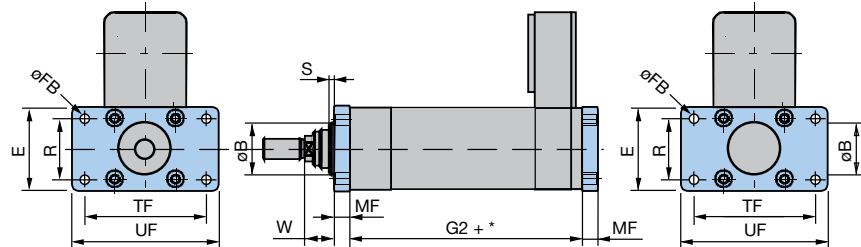
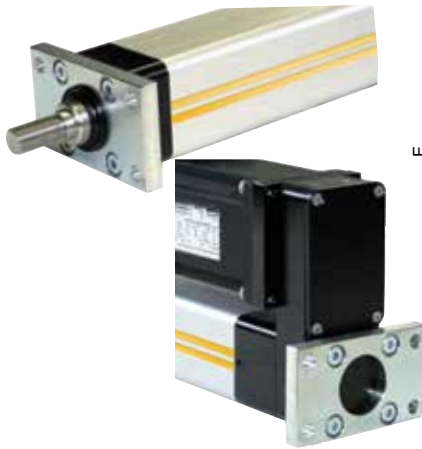

Plate is stainless steel

Cylinder Size	Part Number*	Dimensions – mm								
		S	W	MF	UF	TF	E	R	ØFB	ØB
ETH032	0111.064	2	16	10	80	64	48	32	7	30
ETH050	0121.064	4	25	12	110	90	65	45	9	40
ETH080	0131.064-02	4	30	16	150	126	95	63	12	60

\* Use order code when ordering cylinder; use part number for ordering spare replacement parts (one piece per part number)

## N Front & Rear Plate Mount



Plates are stainless steel

Cylinder Size	Part Number**	Dimensions – mm								
		S	W	MF	UF	TF	E	R	ØFB	ØB
ETH032	Front & Rear 0111.064	2	16	10	80	64	48	32	7	30
ETH050	Front & Rear 0121.064	4	25	12	110	90	65	45	9	40
ETH080	Front 0131.064-02	4	30	16	150	126	95	63	12	60
	Rear 0131.064-01									45

\* Dimension G2+ (parallel) or G1+ (inline) = Dimension + length of desired stroke (see page 40 for calculating stroke)

\*\* Use order code when ordering cylinder; use part number for ordering spare replacement parts (one piece per part number)

# ETH Rod End Options

Order Code

## C Clevis Rod End

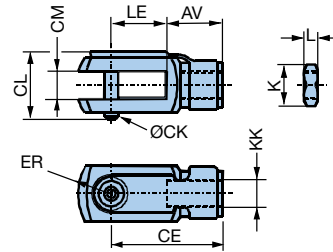

Cylinder Size	Part Number*	Mass [kg]	Dimensions – mm										
			KK	CL	CM	LE	CE	AV	ER	ØCK (h11/E9)	K	L	
ETH032	4309	0.09	M10 x 1.25	26.0	10.2	+0.13/-0.05	20	40	20	14	10	17	5
ETH050	4312	0.34	M16 x 1.5	39.0	16.2	+0.13/-0.05	32	64	32	22	16	24	8
ETH080	4314	0.69	M20 x 1.5	52.5	20.1	+0.02/-0.0	40	80	40	30	20	30	10

\*Use order code when ordering cylinder; use part number for ordering spare replacement parts (cylinder rod with male thread is required)

## F Female Threaded Rod End

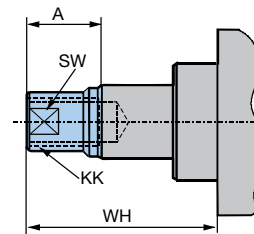

Cylinder Size	Part Number*	Mass [kg]	Dimensions – mm			
			A	KK	WH	SW**
ETH032	0111.029	0.04	14	M10 x 1.25	32	12
ETH050	0121.029	0.14	24	M16 x 1.5	50	20
ETH080	0131.029	0.42	29	M20 x 1.5	59	26

\*Use order code when ordering cylinder; use part number for ordering spare replacement parts

\*\* SW = width across flat (position of the flat is not fixed)

## M Male Threaded Rod End

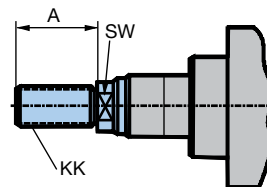

Cylinder Size	Part Number*	Mass [kg]	Dimensions – mm		
			A	KK	SW**
ETH032	0111.028	0.06	22	M10 x 1.25	10
ETH050	0121.028	0.15	32	M16 x 1.5	17
ETH080	0131.028	0.48	40	M20 x 1.5	22

\*Use order code when ordering cylinder; use part number for ordering spare replacement parts

\*\* SW = width across flat (position of the flat is not fixed)

## S Spherical Rod End

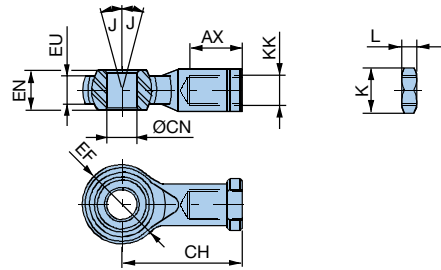

Cylinder Size	Part Number*	Mass [kg]	Dimensions – mm									
			KK	ØCN (H9)	EN (h12)	EU	AX	CH	ØEF	J°	K	L
ETH032	4078-10	0.07	M10 x 1.25	10	14	10.5	20	43	28	13	17	5
ETH050	4078-16	0.23	M16 x 1.5	16	21	15.0	28	64	42	15	24	8
ETH080	4078-20	0.41	M20 x 1.5	20	25	18.0	33	77	50	14	30	10

\* Use order code when ordering cylinder; use part number for ordering spare replacement parts (cylinder rod with male thread is required)

## L Alignment Coupler



The alignment coupler mounts on the end of the cylinder rod to:

- Balance misalignments
- Increase the mounting tolerance
- Simplify cylinder mounting
- Increase cylinder guide service life
- Compensate for offsets between components and relieves guides from lateral force influences
- Maintain traction/thrust force bearing capacity

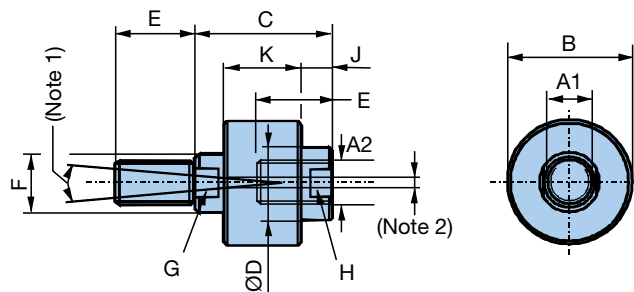

(1) Angle offset  $\pm 5^\circ$  from centerline (2) Axial offset:  $\pm 1.5$  mm from centerline

Cylinder Size	Part Number*	Mass [kg]	Dimensions – mm										
			A1	A2	B	C	ØD	E	F	G	H	J	K
ETH032	LC32-1010	0.26	M10x1.25	M10x1.25	40	51	19	19	16	13	16	13	26
ETH050	LC50-1616	0.64	M16x1.5	M16x1.5	54	59	32	29	25	22	29	14	33
ETH080	LC80-2020	1.30	M20x1.5	M20x1.5	54	59	32	29	25	22	29	14	33

\*Use order code when ordering cylinder; use part number for ordering spare replacement parts (cylinder rod with male thread is required)

# ETH Rod End Options

Order Code

## R Linear Guide Module



### Linear Guide Module offers:

- Anti-rotation control for higher torques
- Absorption of lateral forces

### Additional stability and precision is achieved by:

- 2 hardened stainless steel guiding rods
- 4 linear ball bearings

Not available with IP65 models

### Linear Guide Module Specifications

Cylinder Size	Part Number*	Total Mass (w/Zero Stroke) [kg]	Moving Mass (w/Zero Stroke) [kg]	Additional Mass [kg/m]
ETH032	32-2800R-xxxx	0.97	0.60	1.78
ETH050	50-2800R-xxxx	2.56	1.84	4.93
ETH080	80-2800R-xxxx	6.53	4.36	7.71

\*Use order code when ordering cylinder; use part number for ordering spare replacement parts replacing xxxx with the desired stroke length. For example, order 50-2800R-0200 for 200 mm stroke. (Be sure to specify the same stroke as ordered on the matching ETH cylinder.)

### Deflection\*

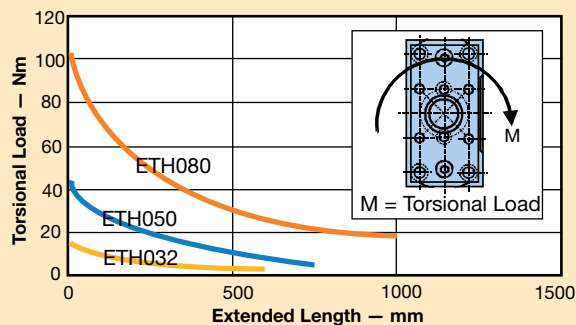
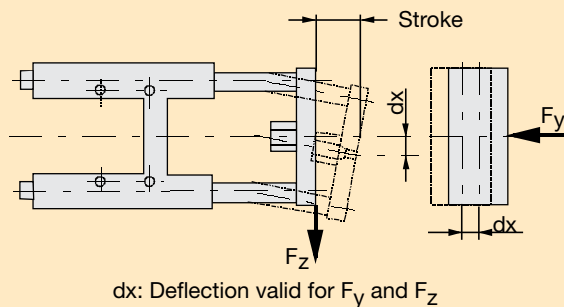

\* Deflection curves represent cylinders mounted in any orientation

### Cylinder Rigidity with Linear Guide Module

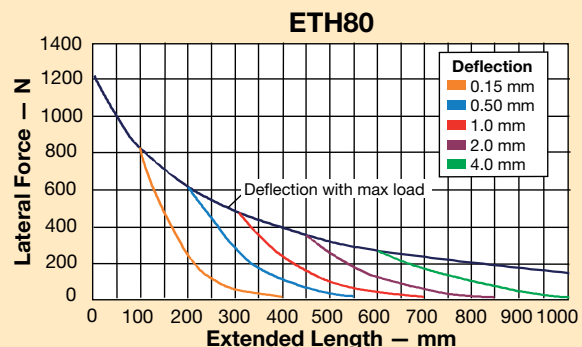
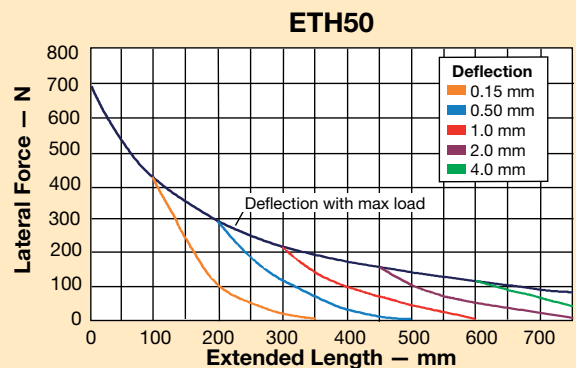
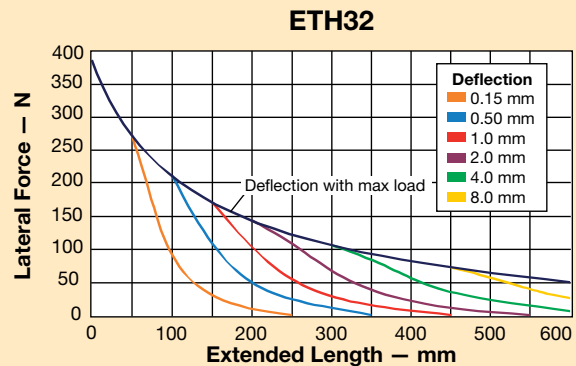



## Linear Guide Module Dimensions

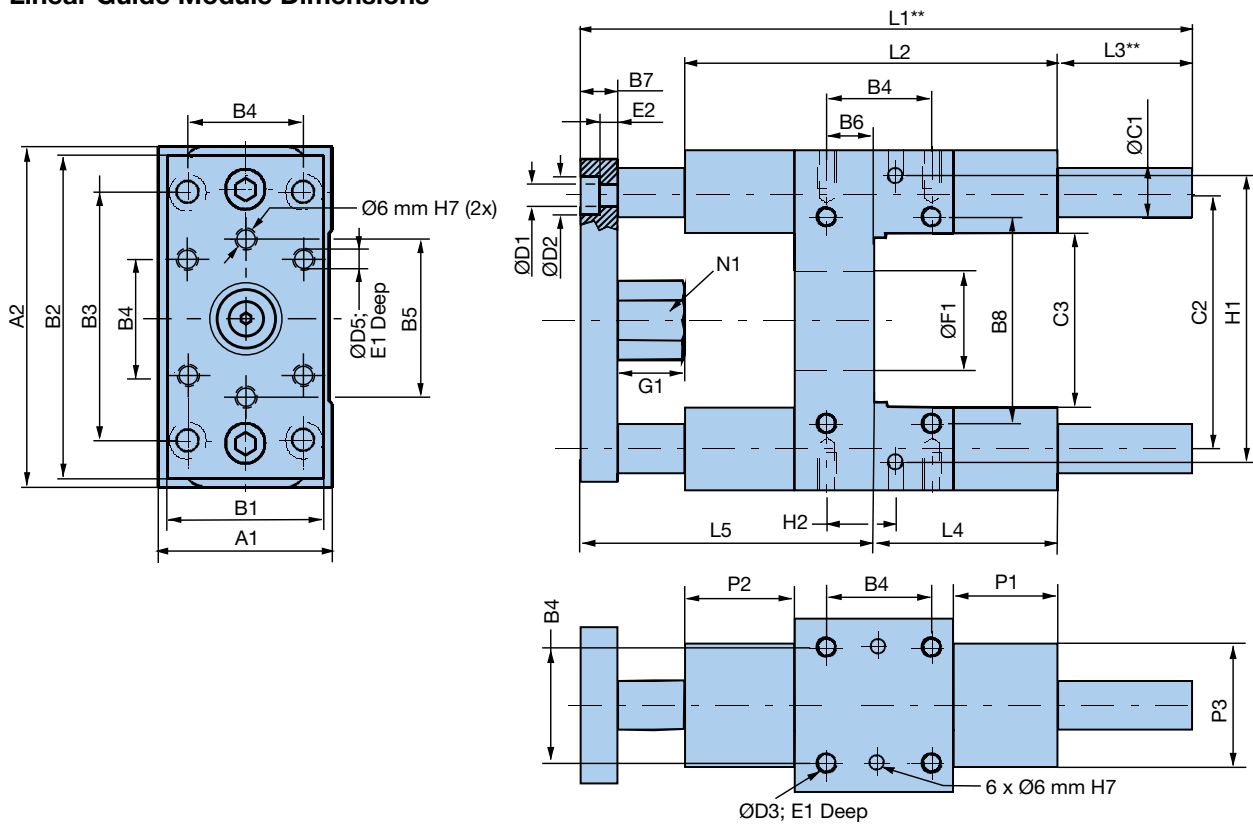

Part Number	Dimensions – mm									
	A1	A2	B1	B2	B3	B4	B5	B6	B7	B8
32-2800R-xxxx	50.0	97.0	45.0	90.0	78.0	32.5	50.0	4.0	12.0	61.0
50-2800R-xxxx	70.0	137.0	63.0	130.0	100.0	46.5	72.0	19.0	15.0	85.0
80-2800R-xxxx	105.0	189.0	100.0	180.0	130.0	72.0	106.0	21.0	20.0	130.0

Part Number	$\text{\O}C1$	C2	C3	$\text{\O}D1$	$\text{\O}D2$	$\text{\O}D3$	E1 (Depth)	E2 (Depth)	$\text{\O}F1$	G1
32-2800R-xxxx	12.0	73.5	50.0	6.6	11.0	M6 x 1.00	12.0	7.25	30.0	17.0
50-2800R-xxxx	20.0	103.5	70.0	8.4	15.0	M8 x 1.25	16.0	9.25	40.0	27.0
80-2800R-xxxx	25.0	147.0	105.0	10.5	18.0	M10 x 1.50	20.0	11.25	60.0	32.0

Part Number	H1	H2	L1+*	L2	L3+*	L4	L5	N1 **	P1	P2	P3
32-2800R-xxxx	81.0	16.0	152.0	120.0	17.0	71.0	64.0	17.0	36.0	31.0	40.0
50-2800R-xxxx	119.0	23.0	193.0	150.0	25.0	79.0	89.0	24.0	42.0	44.0	50.0
80-2800R-xxxx	166.0	36.0	253.0	200.0	30.0	113.0	110.0	30.0	50.0	52.0	70.0

\* L1+ and L3+ = Dimension + length of desired stroke (see page 40 for calculating stroke)

\*\* N1: Hexagon head; Linear guide module not available on IP65 models

# ETH Accessories

## Force Sensor Rod End

### Jointed swivel head design with integrated force sensor

Swivel heads are important construction components with respect to rotary, pivoting and tilting movements. Force measurements are more and more frequently required in those applications.

The force transducers are suitable for direct mounting on the cylinder rod. They can, for example, be used to measure contact forces or overloads.

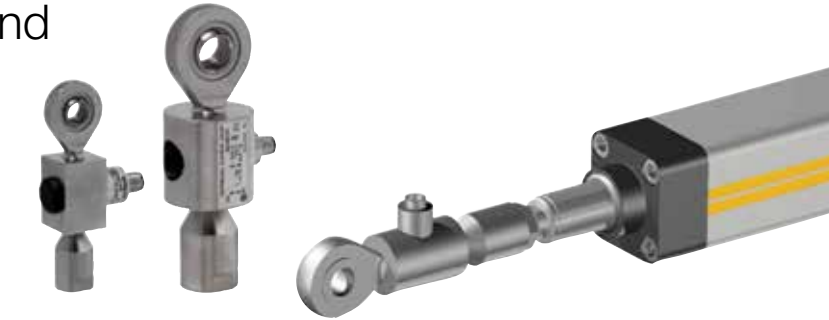

Thanks to thin film technology, the swivel head force transducers are very robust and long time stable. An integrated amplifier emits an output signal of 4 ... 20 mA.

The sensors correspond to the EN 61326 standard for electromagnetic compatibility (EMC) and are sense both thrust and traction forces.

### Features

- **Measuring range: traction/thrust forces up to  $\pm 25$  kN**
- **Thin film implants (instead of conventional bonded foil strain gauges)**
- **Corrosion resistant stainless steel version**
- **Integrated amplifier**
- **Small temperature drift**
- **High long term stability**
- **High shock and vibration resistance**
- **For dynamic or static measurements**
- **Good repeatability**
- **Simple mounting**

Requires male thread rod end option "M", see page 22

	ETH032			ETH050			ETH080		
	M05	M10	M16	M05	M10	M20	M05	M10	M32
<b>Part Number</b>	0111.916	0111.916	0111.917	0121.916	0121.917	0121.918	0131.916	0131.917	0131.918
<b>Accuracy – %</b>	0.2								
<b>Material</b>	Stainless steel								
<b>Protection class</b>	IP67								
<b>Calibration – kN</b>	$\pm 3.7$	$\pm 3.7$	$\pm 2.4$	$\pm 9.3$	$\pm 7.0$	$\pm 4.4$	$\pm 17.8$	$\pm 25.1$	$\pm 10.6$
<b>Accuracy – N</b>	14.8	14.8	9.6	37.2	28.0	17.6	71.2	100.4	42.4

### Electrical Connection

Analog output 4...20 mA (two-wire technology)

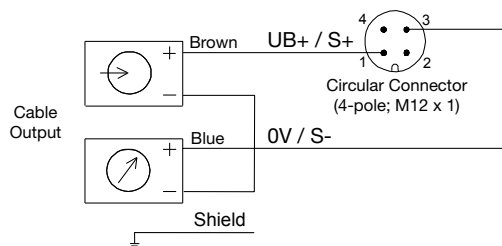

### Force Sensor Cables

Part Number	Description
<b>080-900446</b>	2M sensor cable, straight connector, M12 to flying leads
<b>080-900447</b>	5M sensor cable, straight connector, M12 to flying leads
<b>080-900456</b>	2M sensor cable, 90 degree (symbol) angled connector, M12 to flying leads
<b>080-900457</b>	5M sensor cable, 90 degree (symbol) angled connector, M12 to flying leads

### Force Sensor Rod End for ETH032

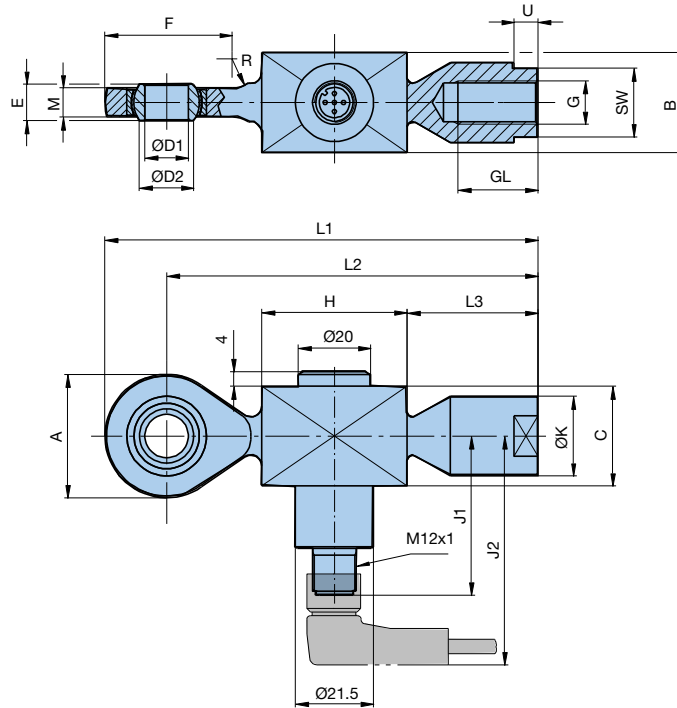

### Force Sensor Rod End for ETH050 & ETH080

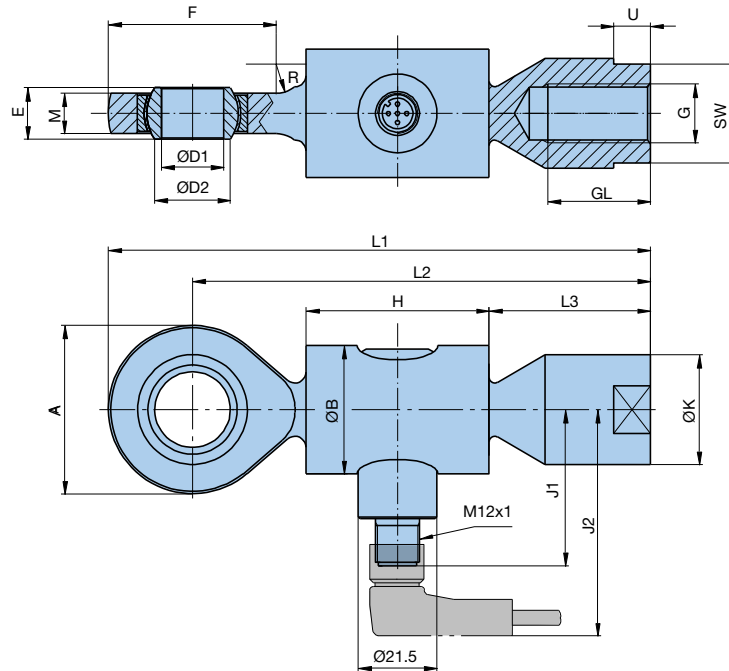

Cylinder Size	Dimensions – mm																			
	A	B	ØB	C	ØD1	ØD2	0.008	E	F	G	GL	H	J1	J2	ØK	L1	L2	L3	M	SW*
ETH032	34	27	—	27	12	15	10	35	M10x1.25	22	40	44	63	22	119	102	36	8	19	8
ETH050	46	—	35	—	17	20.7	14	46	M16x1.5	28	50	43	62	30	148	125	44	11	27	12
ETH080	53	—	54	—	20	24.2	16	54	M20x1.5	33	54	44	63	35	171	144.5	54	13	32	13

\*SW = width across flat

# ETH Accessories

## Force Sensor Rear Clevis

In some force measurement applications, a force sensor on the cylinder rod is not possible or will affect the application's scope. For these applications, Parker developed a special option for the ETH, where the force sensor is integrated into the end-cap of the cylinder. One of the main advantages of this design is that the sensor cable does not move as the rod extends and retracts. All force sensors are configured as traction/thrust sensors.

Analog standard output signals 4...20 mA are available. The sensors correspond to the EN 61326 standard for electromagnetic compatibility (EMC).

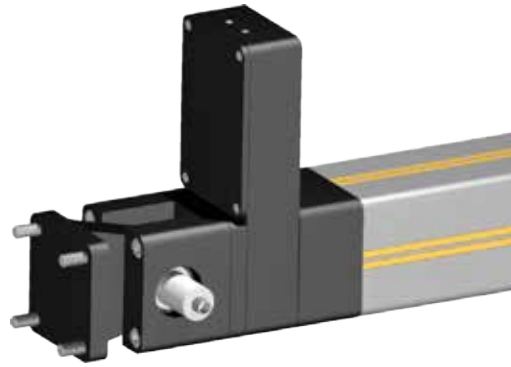

### Features

- **Measuring range: traction/thrust forces up to  $\pm 25$  kN**
- **Thin film implants (instead of conventional bonded foil strain gauges)**
- **Corrosion resistant stainless steel version**
- **Integrated amplifier**
- **Small temperature drift**
- **High long term stability**
- **High shock and vibration resistance**
- **For dynamic or static measurements**
- **Good repeatability**
- **Simple mounting**

Compatible with parallel motor configurations only.

Requires tapped bottom hole cylinder mounting option "F", see page 19.

	ETH032			ETH050			ETH080		
	M05	M10	M16	M05	M10	M20	M05	M10	M32
<b>Part Number</b>	0112.034-01	0112.034-01	0112.034-02	0122.034-01	0122.034-02	0122.034-03	0132.034-01	0132.034-02	0132.034-03
<b>Accuracy – %</b>	1								
<b>Material</b>	Stainless steel								
<b>Protection class</b>	IP67								
<b>Calibration – kN</b>	$\pm 3.7$	$\pm 3.7$	$\pm 2.4$	$\pm 9.3$	$\pm 7.0$	$\pm 4.4$	$\pm 17.8$	$\pm 25.1$	$\pm 10.6$
<b>Accuracy – N</b>	74.0	74.0	48.0	186.0	140.0	88.0	356.0	502.0	212.0

### Electrical Connection

Analog output 4...20 mA (two-wire technology)

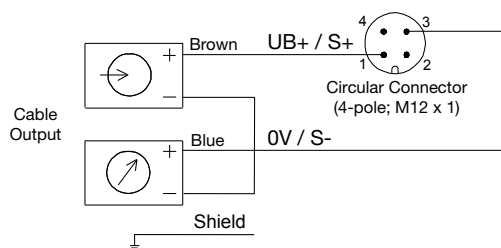

### Force Sensor Cables

Part Number	Description
<b>080-900446</b>	2M sensor cable, straight connector, M12 to flying leads
<b>080-900447</b>	5M sensor cable, straight connector, M12 to flying leads
<b>080-900456</b>	2M sensor cable, 90 degree (symbol) angled connector, M12 to flying leads
<b>080-900457</b>	5M sensor cable, 90 degree (symbol) angled connector, M12 to flying leads

## Force Sensor Rear Clevis for ETH032, ETH050, ETH080

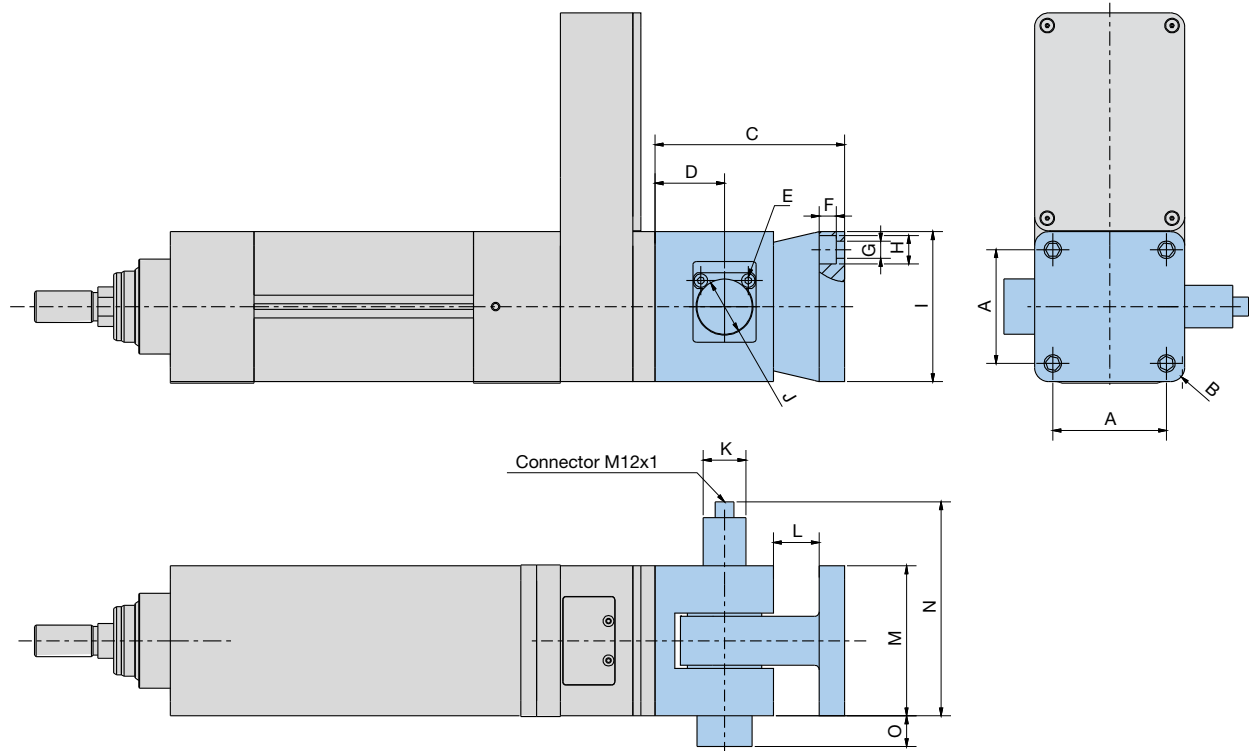

Size	Dimensions – mm														
	A	B	C	D	E*	F	G	H	I	ØJ	ØK	L	M	N	O
<b>ETH032</b>	32.5	R7	72	27	SW3	6.4	6.6	11	46.5	20	27	12	46.5	98.25	6.75
<b>ETH050</b>	46.5	R8.5	89	32	SW3	8.8	9	15	63.5	25	27	17	63.5	111.75	3.25
<b>ETH080</b>	72.0	R9	123	47	SW4	10.8	11	18	95.0	35	27	29	95.0	135.50	0

\*SW = width across flat

# ETH Accessories

## Limit Sensors

The ETH uses the Parker Global Sensor which can be mounted in the longitudinal grooves running along the cylinder body. These new sensors mount flush to the extrusion body, minimizing the overall width of the actuator.

The sensor cable can be concealed under the yellow T-slot covers which are provided with each unit.

Permanent magnets integrated into the screw nut actuate the sensors as the rod extends and retracts.



ETH032 and ETH050 sizes have two grooves on opposite sides of the cylinder; the ETH080 has two grooves on all four sides of the cylinder.

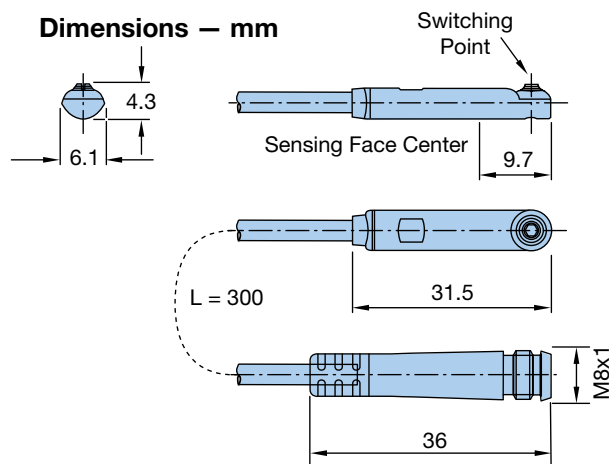

Note: Only PNP logic sensors are compatible with Compax3.

### Common Specifications:

**Electric current drain:** 100 mA (max)

**Switching current:** 10 mA (max)

**Supply voltage:** 10 – 30 VDC

**Switching Frequency:** 5 kHz

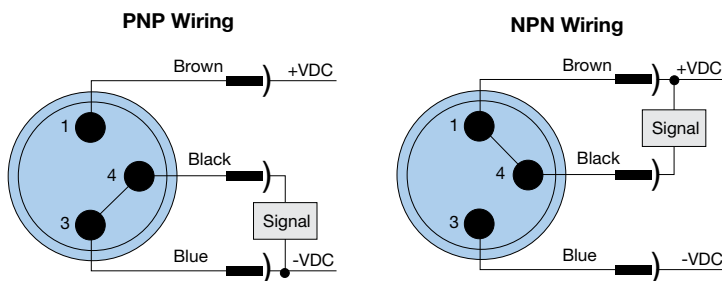

### Magnetic LED Cylinder Sensors

Model Number	Function	Logic	Cable	Compatible w/ Compax3
P8S-GPFAX	N.O.	PNP	3 m	Yes
P8S-GNFAX		NPN		No
P8S-GPCHX		PNP	0.3 m cable with M8 connector*	Yes
P8S-GNCHX		NPN	0.3 m cable with M8 connector*	No
P8S-GQFAX	N.C.	PNP	3 m	Yes
P8S-GMFAX		NPN		No
P8S-GQCHX		PNP	0.3 m cable with M8 connector*	Yes
P8S-GMCHX		NPN	0.3 m cable with M8 connector*	No

\* 003-2918-01 is a 5 m extension cable to flying leads for these cables

# ETH Cylinders Connection with Compax3 Drives/Controllers

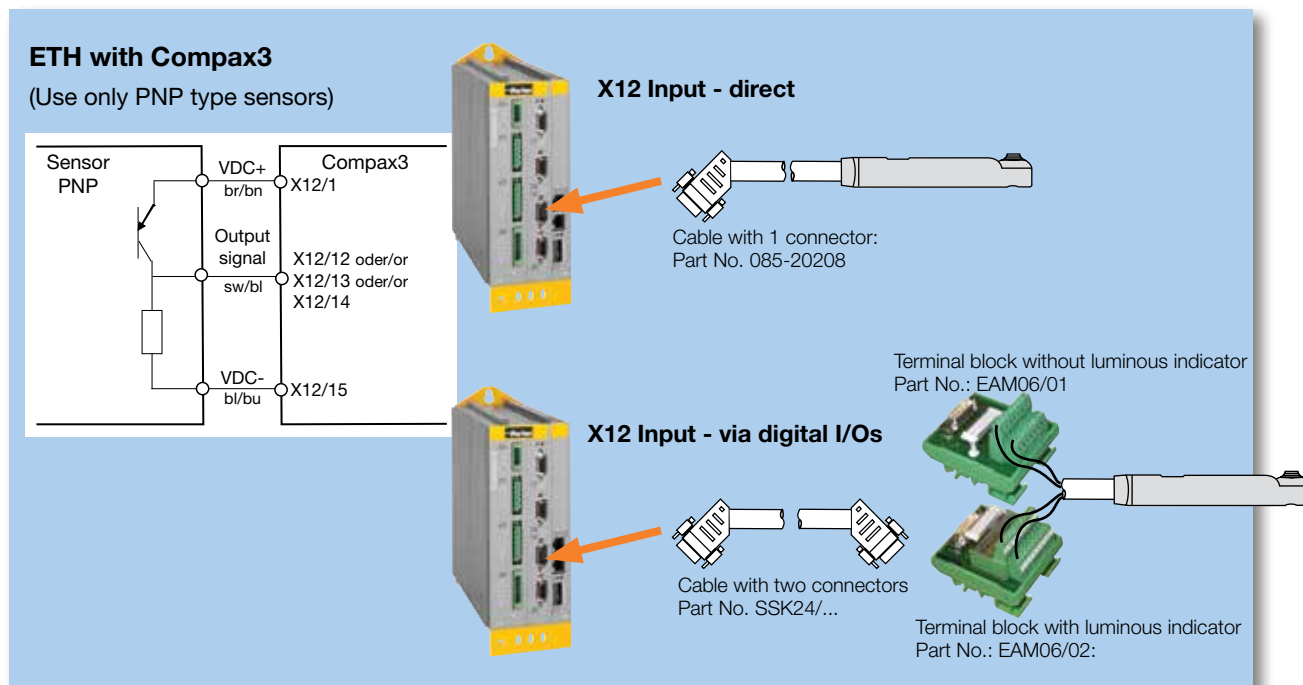

## Xpress Motion Packages

Mounting Code	Motor Part Number	Gearhead Part Number <sup>1</sup>	Recommended Compax3 Servo Drive(s)	Motor Cable	Feedback Cable
XPC	BE233FJ-KPSN	—	C3S063V2F12lxxTxxMxx	P-1A1-xx	
XPD	BE233FJ-KPSB <sup>2</sup>	—			
XPG	BE344LJ-KPSN	—	C3S100V2F12lxxTxxMxx		
XPH	BE344LJ-KPSB	—			
XPL	MPP1003D1E-KPSN	—			
XPM	MPP1003D1E-KPSB	—			
XPN	MPP1003D1E-KPSN	PV34/PV90-003	C3S150V2F12lxxTxxMxx		
XPP	MPP1003D1E-KPSB	PV34/PV90-004			
XPQ	MPP1003R1E-KPSN	—			
XPR	MPP1003R1E-KPSB	—	CS3S063V2F12lxxTxxMxx <sup>3</sup> or C3S075V4F12lxxTxxMxx		F-2C1-xx
XPS	MPP1003R1E-KPSN	PV34/PV90-003		P-3B1-xx	
XPT	MPP1003R1E-KPSB	PV34/PV90-004			
XPU	MPP1154B1E-KPSN	—			
XPV	MPP1154B1E-KPSB	—			
XPW	MPP1154B1E-KPSN	PV115-003	C3S150V2F12lxxTxxMxx		
XPX	MPP1154B1E-KPSB	PV115-004			
XPY	MPP1154P1E-KPSN	—			
XPZ	MPP1154P1E-KPSB	—	CS3S063V2F12lxxTxxMxx <sup>3</sup> or C3S075V4F12lxxTxxMxx		
XP1	MPP1154P1E-KPSN	PV115-003			
XP2	MPP1154P1E-KPSB	PV115-004			

<sup>1</sup> PV34 will be used for all inline motor mounting configurations. PV90 will be used when the motor is mounted in parallel.

<sup>2</sup> BE233FJ-KPSN with a brake (CM233FJ-115027)

<sup>3</sup> Motors are rated for 460 volts AC. This combination, with the 230 volt drive, will result in motor running at 1/2 its rated speed

# Sizing/Selection

## How to use Speed Thrust Curves

### Option 1: Xpress System Sizing

Parker offers pre-selected motor and motor/gearhead combinations to maximize the power output of each ETH frame size. This option is ideal for customer's working on time-sensitive applications and/or those that value the many benefits of a single-source solution.

To select the system solution, use the graphs on pages 33-38 to locate the application's required linear velocity and thrust.

If the point lies within a green shaded region, and it is not to the right of the relevant critical speed line, then the application can be solved with the motor or motor/gearhead combination corresponding to the number in that region while still getting full rated life (2,540 Km).

If the point is in the yellow intermittent zone, then the actuator will experience a reduced life, in

which case another screw lead or a larger profile size is recommended.

If the point falls above the solid blue line, then the application cannot be solved with that actuator profile size and lead combination when using a motor mounted in parallel.

Once a solution is found simply order the ETH with the correct Xpress motor code and pair with the recommended Compax3 drive and motor power and feedback cables from page 31 to complete the Xpress system.

#### Performance Zones:

Motor Codes	Continuous Operation
	①
XPG <sup>(1)</sup>	•
XPH <sup>(2)</sup>	•

<sup>(1)</sup> Without brake <sup>(2)</sup> With brake  
\* In-line motor mount only

#### Example:

For an application needing 1000 N thrust at 400 mm/sec velocity, both the XPG and XPH motor/gearhead combinations will solve the application. Note: the actuator stroke must be less than approximately 900 mm in order to reach the required speed.

#### Solution:

**Cylinder:** ETH050M10xxXPGxxxxxxxxx

**Servo motor:** BE344LJ-KPSN

**Drive:** C3S100V2F12IxxTxxMxx

**Cables:** P-3B1-xx and F-2C1-xx

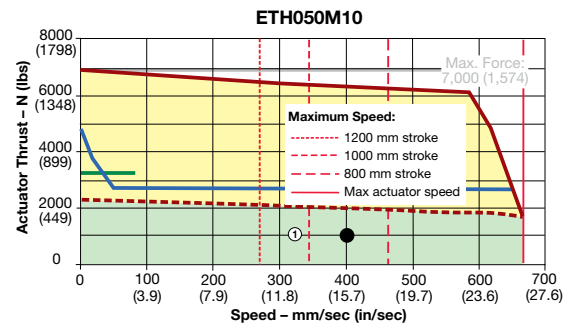

### Option 2: Hybrid Speed/Thrust Graphs

Back by popular demand, Parker has recreated the hybrid speed/thrust graphs for the new ETH Series actuators. These graphs are an ideal way to size an actuator for non-Xpress or third-party motors. These speed/thrust graphs plot linear velocity, linear thrust, required motor velocity, required motor torque, and critical speed.

To select a motor or motor/gearhead combination, use the graphs on pages 7-9 to locate the application's required linear velocity and thrust on the graph.

Once that point is determined, extend the lines to the secondary

axes to determine the required motor torque and motor speed for the application.

Once the motor requirements are known, simply order the ETH with the proper Parker motor or gearhead mounting kits or use one of the non-standard mounting kit options.

#### Example:

For an application needing 1000 N thrust at 400 mm/sec linear velocity, and requiring a

minimum life of 2,540 Km, the motor would have to be sized for 2 Nm of torque at 40 rps. Note: the actuator stroke must be less than approximately 900 mm to reach the required speed.

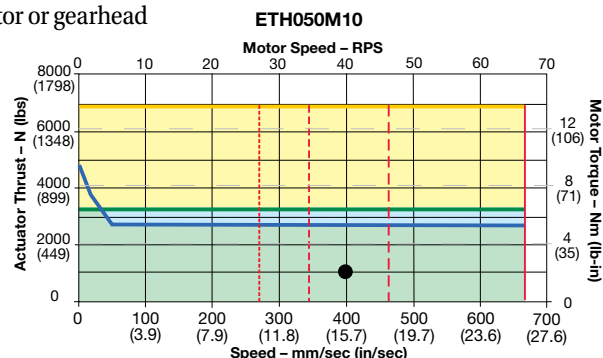

### Option 3: Traditional Step-by-step Selection Process

For the most dynamic applications, or to double check critical application elements when using sizing options 1 and

2, the traditional step-by-step process (starting on page 39), can be used to size the ETH cylinder.



# ETH032 Speed-Thrust with Motors (170 VDC)

## Maximum Thrust with Motor\*:

- Parallel motor mount limitation
- Max thrust w/2540 km life (see page 45 for details)

## XPC – BE233FJ

- Peak
- - - Continuous

## XPG – BE344LJ

- Peak
- - - Continuous

## Maximum Speed:

- - - 1000 mm stroke
- - - 800 mm stroke
- - - 600 mm stroke
- Max actuator speed

## Performance Zones:

Motor Codes	Continuous Operation		
	①	②	③
XPC <sup>(1)</sup>	•		
XPD <sup>(2)</sup>	•		
XPG <sup>(1)</sup>	•	•	•*
XPH <sup>(2)</sup>	•	•	•*

<sup>(1)</sup> Without brake    <sup>(2)</sup> With brake

\* In-line motor mount only

**Intermittent Zone – Consult Factory**  
(operation will result in reduced life of the actuator and is not acceptable for parallel motor options if above the parallel motor mount limitation curve)

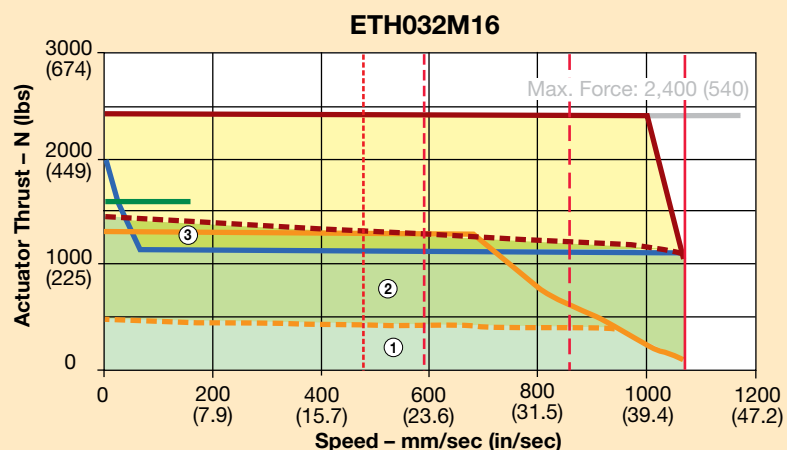
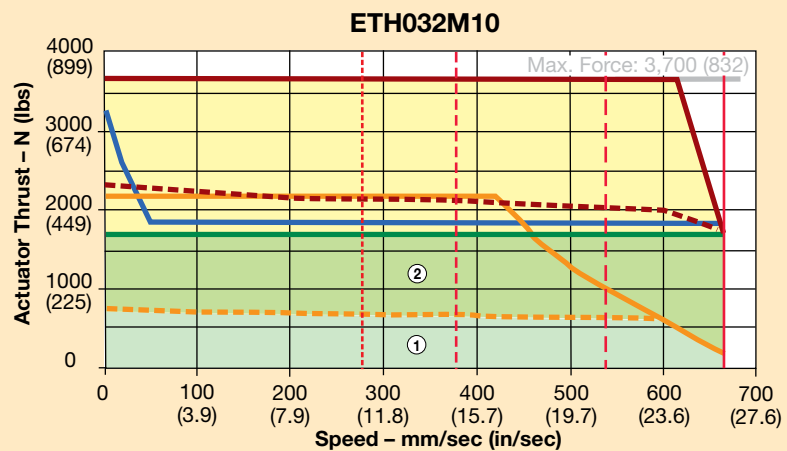
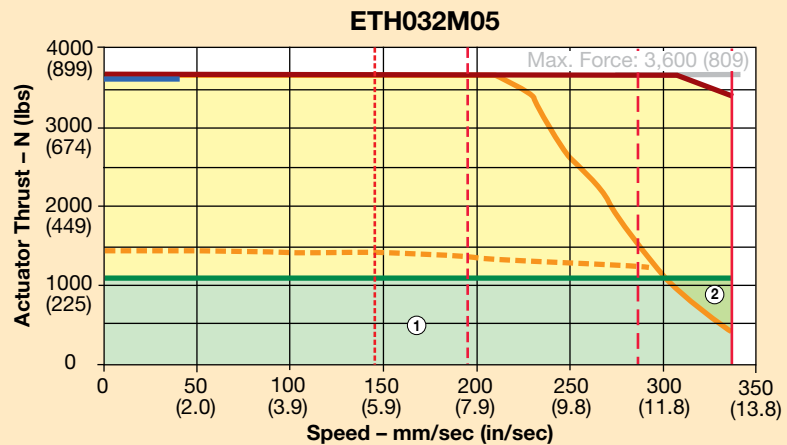

\* Maximum thrust assumes a cylinder mounting orientation with a fixed mounting position and a guided load. For limitations on column buckling, please see page 43.

# Sizing/Selection

## ETH032 Speed-Thrust with Motors (340 VDC)

### Maximum Thrust with Motor\*:

- Parallel motor mount limitation
- Max thrust w/2540 km life (see page 45 for details)

### XPC – BE233FJ

- Peak
- - - Continuous

### XPG – BE344LJ

- Peak
- - - Continuous

### Maximum Speed:

- - - 1000 mm stroke
- - - 800 mm stroke
- - - 600 mm stroke
- Max actuator speed

### Performance Zones:

Motor Codes	Continuous Operation		
	①	②	③
XPC <sup>(1)</sup>	•		
XPD <sup>(2)</sup>	•		
XPG <sup>(1)</sup>	•	•	•*
XPH <sup>(2)</sup>	•	•	•*

<sup>(1)</sup> Without brake    <sup>(2)</sup> With brake

\* In-line motor mount only

**Intermittent Zone – Consult Factory**  
(operation will result in reduced life of the actuator and is not acceptable for parallel motor options if above the parallel motor mount limitation curve)

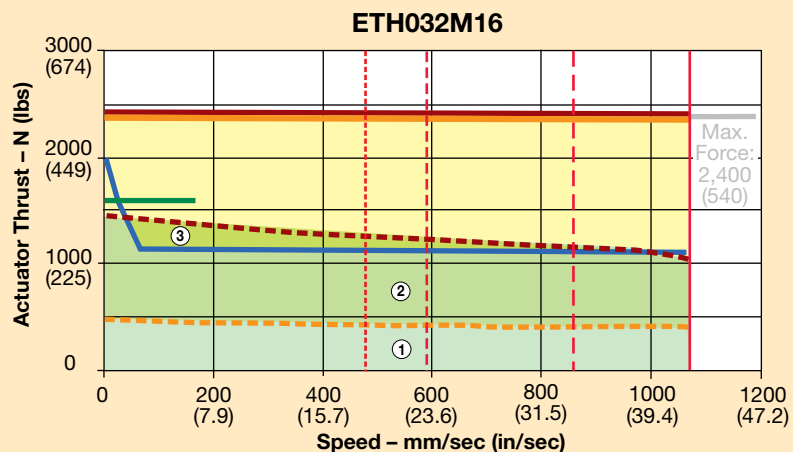
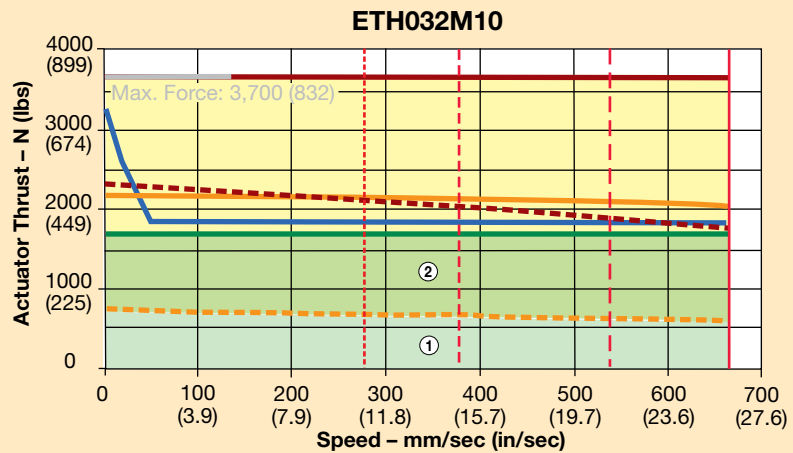
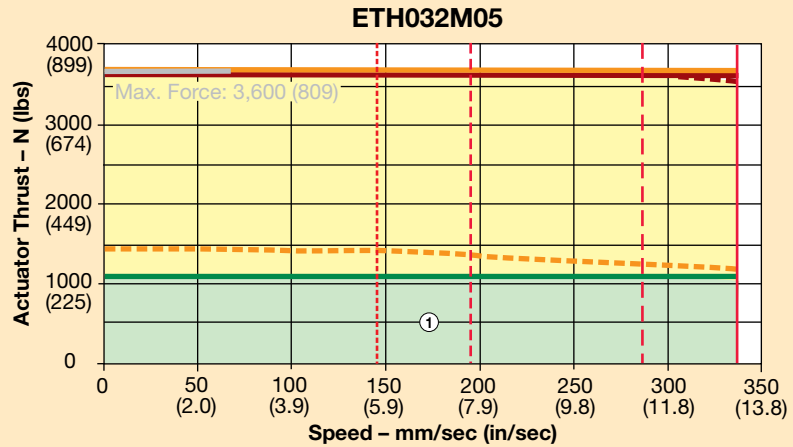

\* Maximum thrust assumes a cylinder mounting orientation with a fixed mounting position and a guided load. For limitations on column buckling, please see page 43.

# ETH050 Speed-Thrust with Motors (170 VDC)

## Maximum Thrust with Motor\*:

- Parallel motor mount limitation
- Max thrust w/2540 km life (see page 45 for details)

## XPG – BE344LJ

- Peak
- - - Continuous

## Maximum Speed:

- - - 1200 mm stroke
- - - 1000 mm stroke
- - - 800 mm stroke
- Max actuator speed

## Performance Zones:

Motor Codes	Continuous Operation
	①
XPG <sup>(1)</sup>	•
XPH <sup>(2)</sup>	•

<sup>(1)</sup> Without brake    <sup>(2)</sup> With brake  
\* In-line motor mount only

**Intermittent Zone – Consult Factory**  
(operation will result in reduced life of the actuator and is not acceptable for parallel motor options if above the parallel motor mount limitation curve)

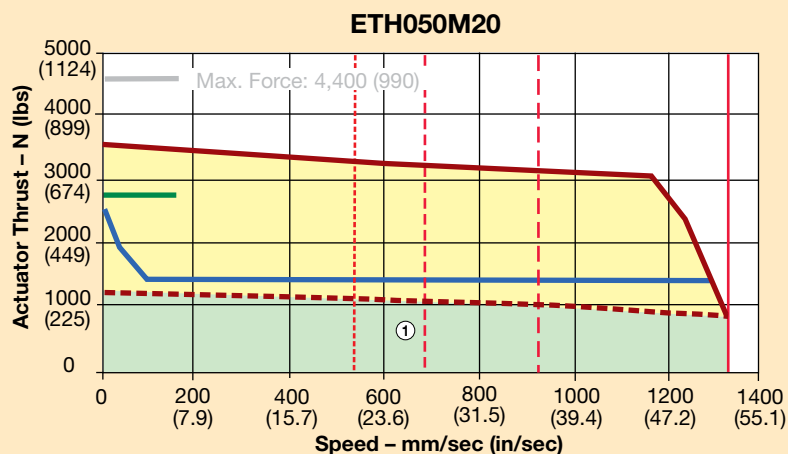
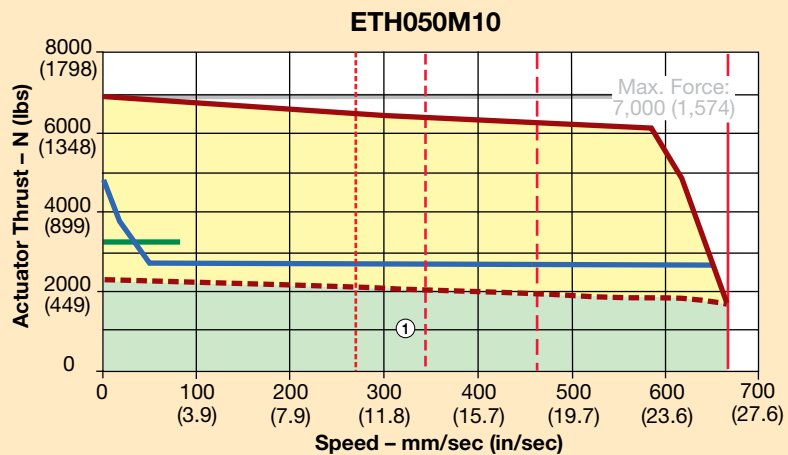
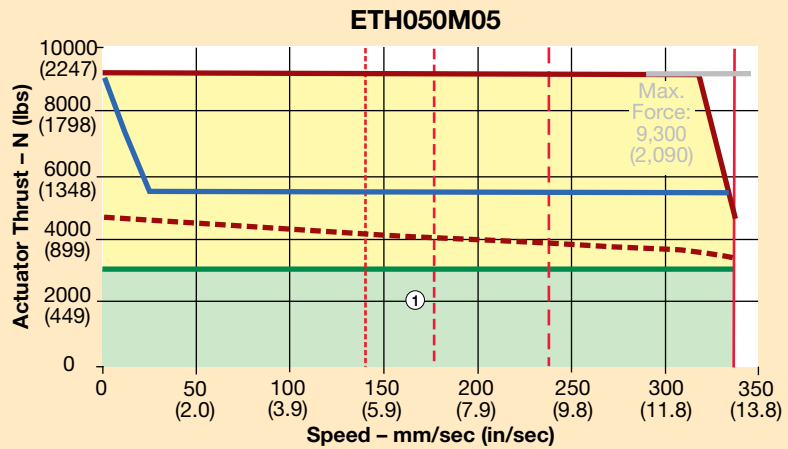

\* Maximum thrust assumes a cylinder mounting orientation with a fixed mounting position and a guided load. For limitations on column buckling, please see page 43.

# Sizing/Selection

## ETH050 Speed-Thrust with Motors (340 VDC)

### Maximum Thrust with Motor\*:

- Parallel motor mount limitation
- Max thrust w/2540 km life (see page 45 for details)

### XPL – MPP1003D1E

- Peak
- Continuous

### XPN – MPP1003D1E (with PV34FE-003)

- Peak
- Continuous

### Maximum Speed:

- 1200 mm stroke
- 1000 mm stroke
- 800 mm stroke
- Max actuator speed

### Performance Zones:

Motor Codes	Continuous Operation			
	①	②	③	④
XPL <sup>(1)</sup>	•		•	
XPM <sup>(2)</sup>	•		•	
XPN <sup>(1)</sup>	•	•		•*
XPP <sup>(2)</sup>	•	•		•*

<sup>(1)</sup> Without brake    <sup>(2)</sup> With brake  
\* In-line motor mount only

**Intermittent Zone – Consult Factory**  
(operation will result in reduced life of the actuator and is not acceptable for parallel motor options if above the parallel motor mount limitation curve)

### ETH050M05

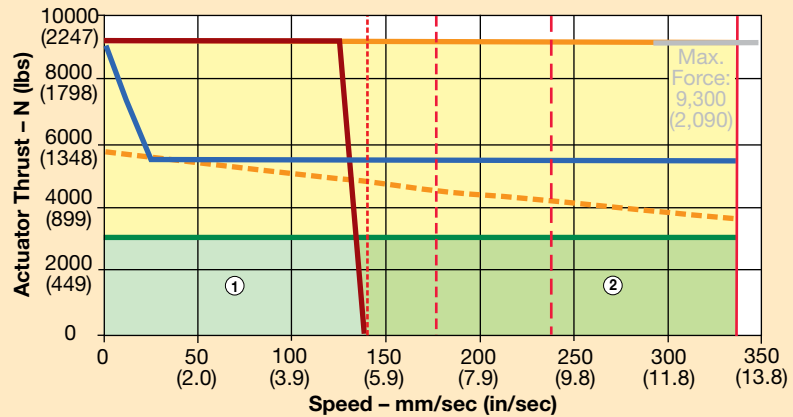

### ETH050M10

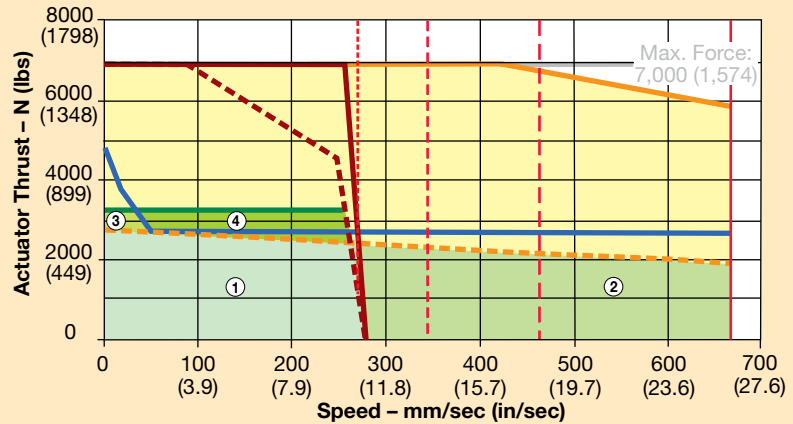

### ETH050M20

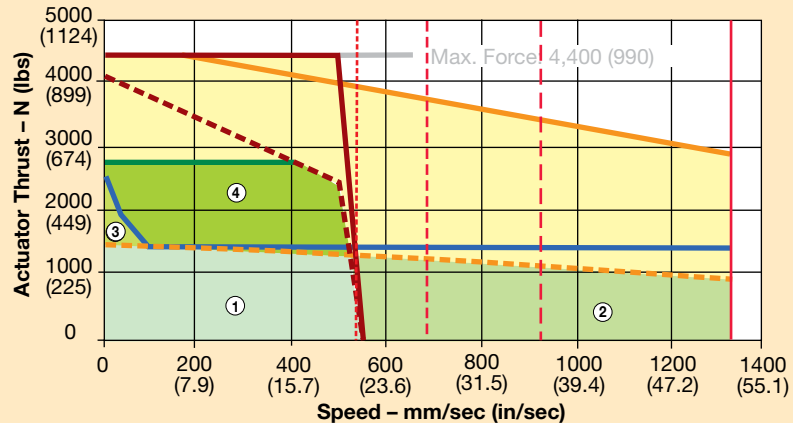

\* Maximum thrust assumes a cylinder mounting orientation with a fixed mounting position and a guided load. For limitations on column buckling, please see page 43.

# ETH050 Speed-Thrust with Motors (680 VDC)

## Maximum Thrust with Motor\*:

- Parallel motor mount limitation
- Max thrust w/2540 km life (see page 45 for details)

## XPQ – MPP1003R1E

- Peak
- Continuous

## XPS – MPP1003R1E (with PV34FE-003)

- Peak
- Continuous

## Maximum Speed:

- 1200 mm stroke
- 1000 mm stroke
- 800 mm stroke
- Max actuator speed

## Performance Zones:

Motor Codes	Continuous Operation			
	①	②	③	④
XPQ <sup>(1)</sup>	•		•	
XPR <sup>(2)</sup>	•		•	
XPS <sup>(1)</sup>	•	•		•*
XPT <sup>(2)</sup>	•	•		•*

<sup>(1)</sup> Without brake    <sup>(2)</sup> With brake  
\* In-line motor mount only

**Intermittent Zone – Consult Factory**  
(operation will result in reduced life of the actuator and is not acceptable for parallel motor options if above the parallel motor mount limitation curve)

### ETH050M05

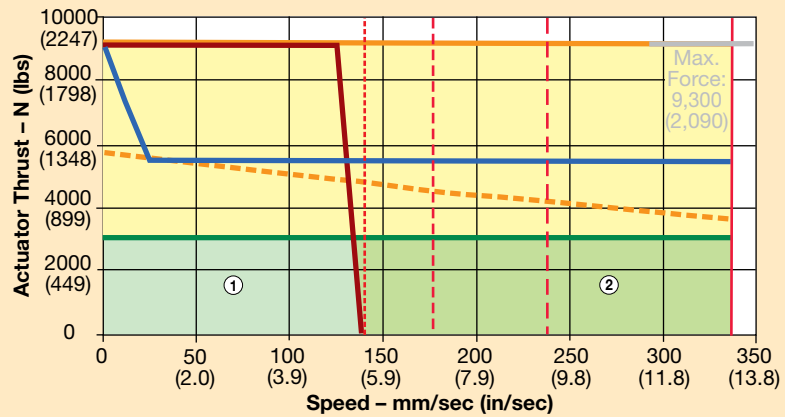

### ETH050M10

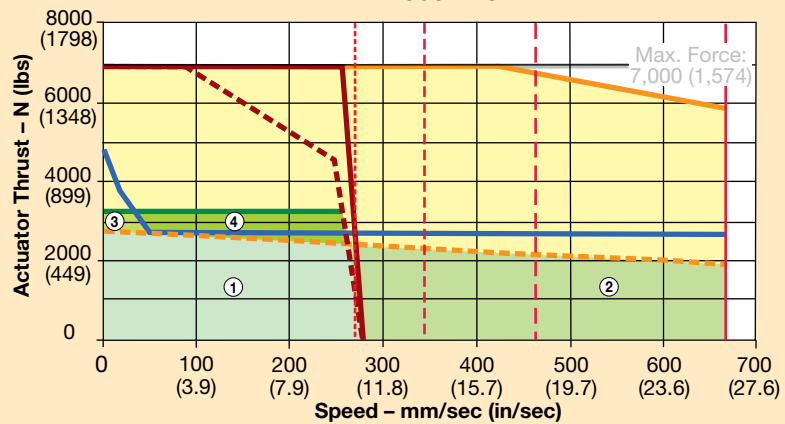

### ETH050M20

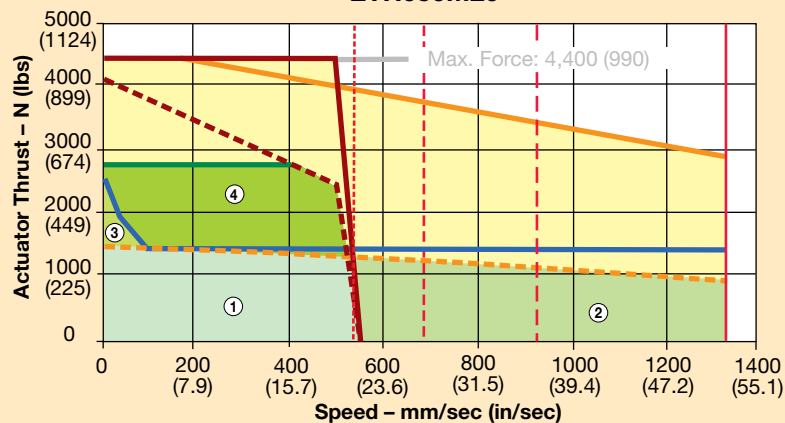

\* Maximum thrust assumes a cylinder mounting orientation with a fixed mounting position and a guided load. For limitations on column buckling, please see page 43.

# Sizing/Selection

## ETH080 Speed-Thrust with Motors (340 & 680 VDC)

### Maximum Thrust with Motor\*:

- Parallel motor mount limitation
- Max thrust w/2540 km life (see page 45 for details)

### XPQ – MPP1003R1E

- Peak
- Continuous

### XPS – MPP1003R1E (with PV34FE-003)

- Peak
- Continuous

### XPU – MPP1154B1E

- Peak
- Continuous

### XPW – MPP1154B1E (with PV115-003)

- Peak
- Continuous

### Maximum Speed:

- 1600 mm stroke
- 1400 mm stroke
- 1200 mm stroke
- 1000 mm stroke
- Max actuator speed

### Performance Zones:

Motor Codes	Continuous Operation					
	①	②	③	④	⑤	⑥
XPQ <sup>(1)</sup>	•	•	•			
XPR <sup>(2)</sup>	•	•	•			
XPS <sup>(1)</sup>	•	•	•	•		
XPT <sup>(2)</sup>	•	•	•	•		
XPU <sup>(1)</sup>	•	•	•	•		
XPV <sup>(2)</sup>	•	•	•	•		
XPW <sup>(1)</sup>	•			•	•	•*
XPX <sup>(2)</sup>	•			•	•	•*

<sup>(1)</sup> Without brake <sup>(2)</sup> With brake

\* In-line motor mount only

**Intermittent Zone – Consult Factory**  
(operation will result in reduced life of the actuator and is not acceptable for parallel motor options if above the parallel motor mount limitation curve)

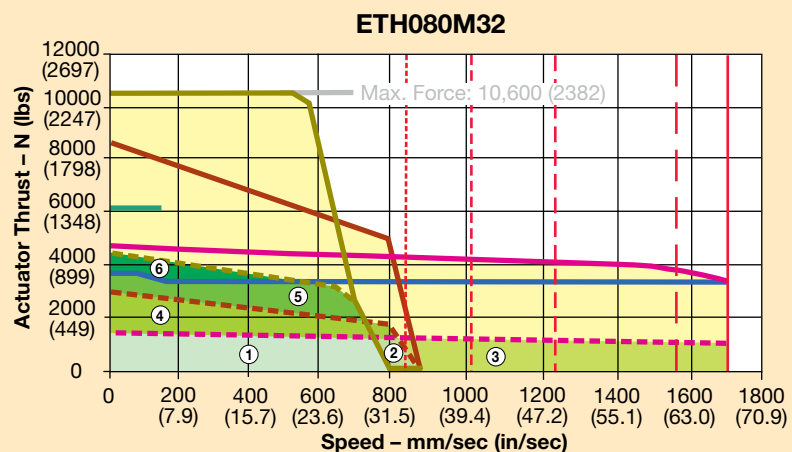
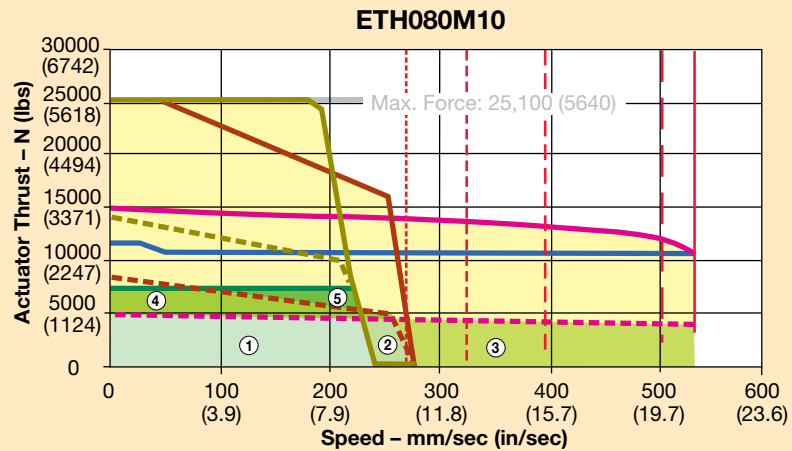
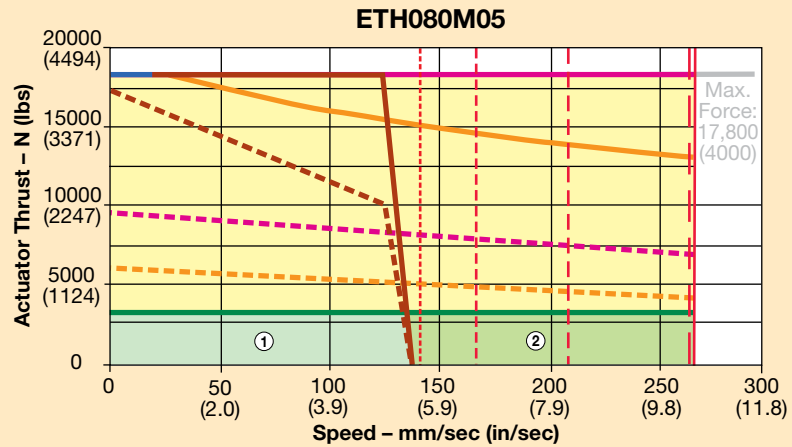

\* Maximum thrust assumes a cylinder mounting orientation with a fixed mounting position and a guided load. For limitations on column buckling, please see page 43.

# Sizing/Selection Design Considerations

Step	Sizing/Selection Design Consideration	Recommendation	See Page
1	<b>Basic Operating Parameters</b>	Check the basic conditions for the use of the ETH in your application. Use the performance chart (page 6) and the speed-thrust graphs (pages 7-9), to confirm the ETH can meet your application's basic performance (e.g. force, velocity, acceleration) mechanical and environmental conditions	6, 7 – 9
2	<b>Required Space</b>	Check the space available in your application and choose the appropriate motor mounting option: inline or parallel. Basic cylinder dimensions, along with dimensions for motor mounting options, can be found on pages 10 - 17.	10 – 17
3	<b>Maximum Velocity</b>	Select the screw lead required to reach the application's maximum velocity	6, 7 – 9
4	<b>Maximum Acceleration</b>	Verify that the maximum acceleration does not exceed the cylinder's limits	6
5	<b>Axial Forces</b>	Calculate the axial forces required in the individual segments of the application.	42
6	<b>Maximum Force Required</b>	Determine the maximum required axial force that the electric cylinder must provide.	42
7	<b>Select Stroke</b>	Determine the usable stroke and safety travels required for the application, then:	40
		<ul style="list-style-type: none"> <li>Select the desired stroke from the list of standard strokes</li> <li>Or, if standard stroke will not work choose a desired stroke in steps of one mm. Please do not exceed the maximum permissible stroke given for each frame size.</li> </ul>	6, 49 6
8	<b>Buckling Risk</b>	Check that the maximum required axial force does not exceed the rod buckling limitations.	43
9	<b>Service Life</b>	Calculate the service life using the equivalent axial forces, the operational environment (application factor), and the load-life curves.	44 – 45
10	<b>Lateral Forces/Side Loads</b>	Determine the lateral forces present in the application and compare them to the permissible lateral forces for the cylinder.	41
11	<b>Relubrication</b>	Determine the lubricating cycle (maintenance schedule) and check that it is suitable.	46
12	<b>Motor/Gearhead Selection</b>	Calculate the required torque needed to generate the required force of the ETH.	47
13	<b>Motor Mounting Flange</b>	Select a suitable motor mounting flange	10 – 17
14	<b>Mounting Type</b>	Select the mounting method of the electric cylinder	18 – 21
15	<b>Cylinder Rod End</b>	Select the desired rod end for load mounting	22 – 24
16	<b>Model number</b>	Develop model number	48 – 49

# Sizing/Selection

## Design Considerations — Stroke, Usable Stroke and Safety Travel

### Stroke:

The stroke to be indicated in the order code is the mechanically maximal possible stroke, which is the stroke between the internal end stops.

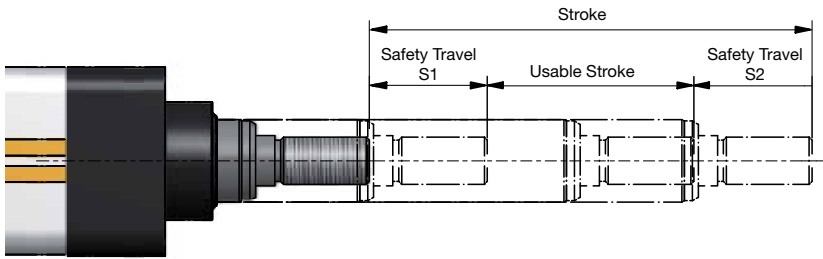

### Usable Stroke:

The usable stroke is the distance needed for the application. It is always shorter than the stroke.

### Safety Travel (S1 & S2)

The safety travels are required to slow down the cylinder after it has passed a limit switch, Emergency stop in order to avoid contact with the mechanical limit stops.

Depending on the screw lead and the maximum speed, the following diagram recommends

a minimum safety travel, which is sufficient for most applications according to experience.

With demanding applications (great masses and high dynamic), the safety travel has to be calculated and enlarged accordingly (dimensioning on demand).

The safety travel shown in the diagram is for one direction only. The diagram value must be multiplied by two for the total safety travel for both extend and retract directions.

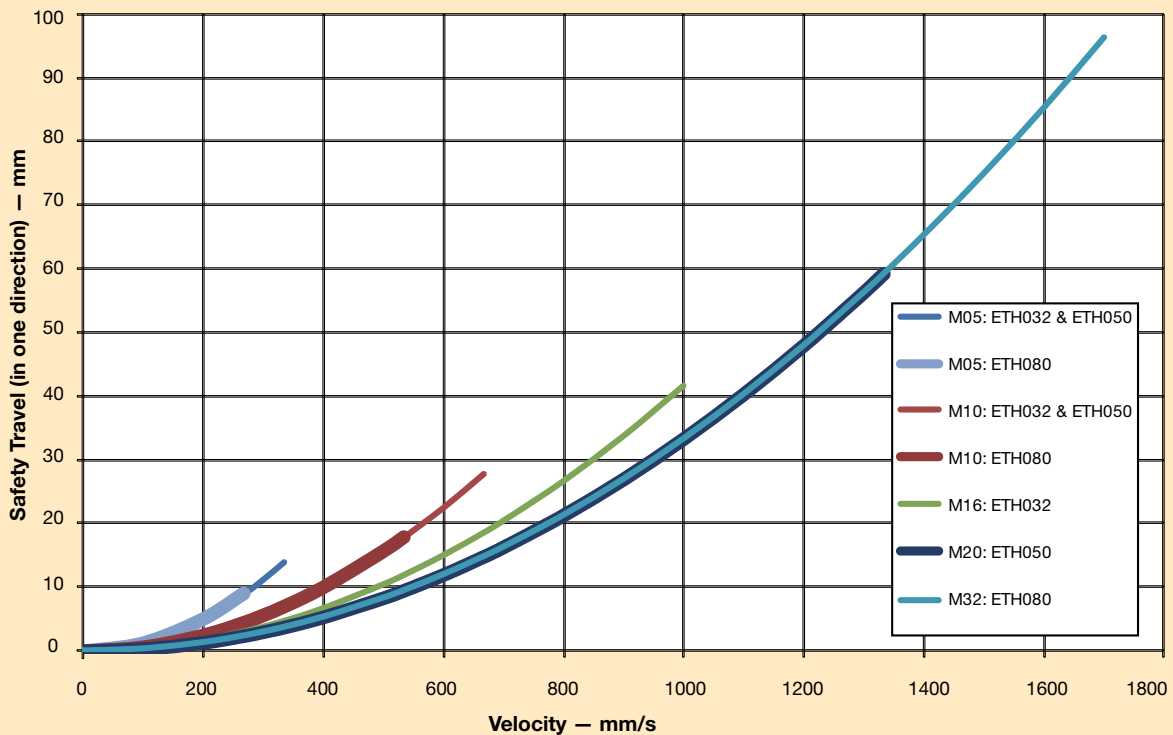



# Sizing/Selection

## Design Considerations – Permissible Side Load

The electric cylinder features a generously dimensioned cylinder rod and screw nut bearing in the form of high-quality plastic sliding bushings to absorb the lateral force.

Please note that electric cylinders with a longer stroke permit a higher lateral force at the same extension length. It may therefore

be useful to choose a longer stroke than required for the application in order to increase the permissible lateral force.

If the permissible lateral forces are exceeded or if the maximum axial force occurs at the same time, the optional outrigger bearing (option R) must be used.

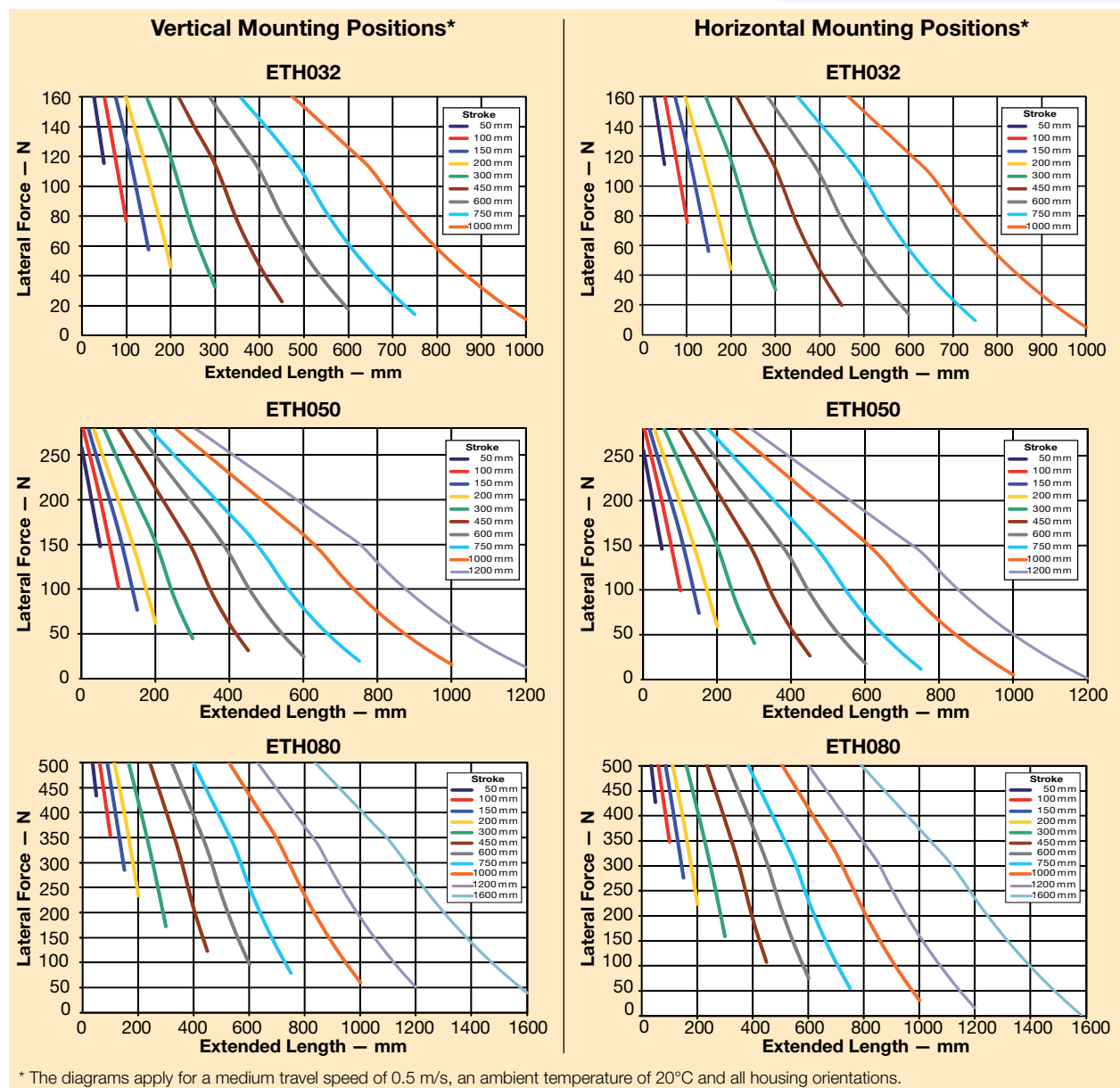
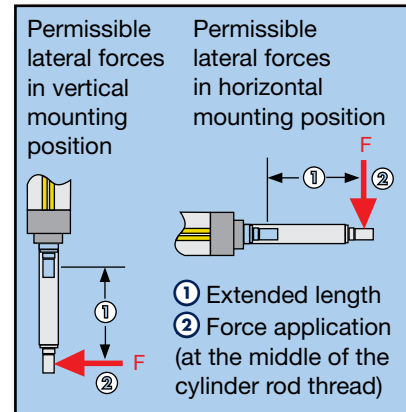

# Sizing/Selection

## Design Considerations — Calculating Axial Force

Use the equations below to calculate the thrust required to extend and retract the piston rod.

Once the individual segments are calculated, the maximum required axial force can be determined. This maximum axial force is used to determine the size of the cylinder and to check that the buckling load limit is not exceeded (see page 43). Note that the axial forces calculated for each segment are later used as the calculation basis for the service life (see page 44)

### Calculation of Axial Forces:

Determine the axial forces occurring during each individual segment of the application cycle. (Index “j” for the individual segments of the application cycle.)

#### Cylinder Rod Extending:

$$F_{x,a,j} = \left| F_{x,ext} + (m_{ext} + m_{Kse} + m_{Ks,0} + m_{Ks,Hub} \cdot \text{Hub}) \cdot (a_{K,j} + \sin \alpha \cdot 9,81 \frac{m}{s^2}) \right|$$

#### Cylinder Rod Retracting:

$$F_{x,e,j} = \left| - F_{x,ext} + (m_{ext} + m_{Kse} + m_{Ks,0} + m_{Ks,Stroke} \cdot \text{Stroke}) \cdot (a_{K,j} + \sin \alpha \cdot 9,81 \frac{m}{s^2}) \right|$$

The values  $F_{x,a,j}$  and  $F_{x,e,j}$  are always positive.

### Formula Abbreviations

$F_{x,a,j}$	Axial forces during extension (N)
$F_{x,e,j}$	Axial forces during retraction (N)
$F_{x,ext}$	External axial force (N)
$F_{G,ext}$	Weight force caused by an additional mass (N)
$F_{G,Kse}$	Weight force caused by the cylinder rod end (N)
$F_{G,Ks}$	Weight force caused by the cylinder rod (N)
$m_{ext}$	Additional mass (kg)
$m_{Kse}$	Mass of the cylinder rod end (kg) (see “Rod End Options” pages 22 - 25)
$m_{Ks,0}$	Mass of the cylinder rod at zero stroke in kg (see page 6)
$m_{Ks,stroke}$	Mass of the cylinder rod per mm of stroke (kg) (see page 6)
<b>Stroke</b>	Selected stroke (m)
$a_{K,j}$	Acceleration at the cylinder rod ( $m/s^2$ )
$\alpha$	Alignment angle ( $^\circ$ )
$F_{x,max}$	Maximum permissible axial force (N)

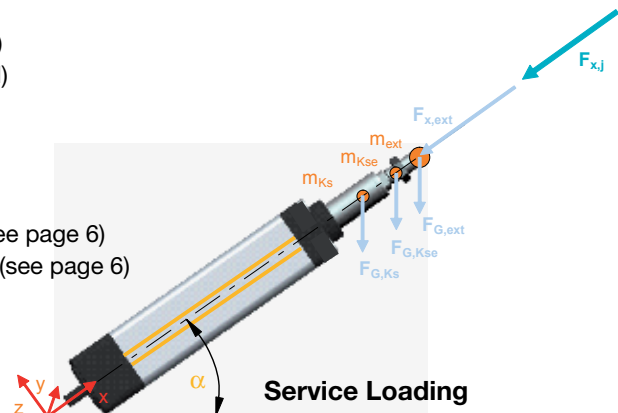

Index “j” for the individual segments of the application cycle

### Example Calculation

**Vertical Mounting**

- ETH50
- Stroke = 500 mm = 0.5 m
- Pitch = 5 mm
- Rod End: External thread
- Trapezoidal velocity course
- Acceleration  $a_k = 4 \text{ m/s}^2$
- $m_{ext} = 150 \text{ kg}$
- $F_{x,ext} = 1000 \text{ N}$
- $m_{Kse} = 0.15 \text{ kg}$
- $m_{Ks,0} = 0.15 \text{ kg}$
- $m_{Ks,Stroke} = 1.85 \text{ kg/m}$
- Alignment angle  $\alpha = -90^\circ$

**Trapezoidal Velocity Course**

---

**Thrust rod extending: Mass is moved downwards**

Load case: Acceleration

$$F_{x,1} = \left| 1000 \text{ N} + \left( 150 \text{ kg} + 0,15 \text{ kg} + 0,15 \text{ kg} + 1,85 \frac{\text{kg}}{\text{m}} \cdot 0,5 \text{ m} \right) \cdot \left( 4 \frac{\text{m}}{\text{s}^2} + \sin(-90^\circ) \cdot 9,81 \frac{\text{m}}{\text{s}^2} \right) \right| = 121 \text{ N}$$

Load case: Constant Velocity

$$F_{x,2} = \left| 1000 \text{ N} + \left( 150 \text{ kg} + 0,15 \text{ kg} + 0,15 \text{ kg} + 1,85 \frac{\text{kg}}{\text{m}} \cdot 0,5 \text{ m} \right) \cdot \left( 0 \frac{\text{m}}{\text{s}^2} + \sin(-90^\circ) \cdot 9,81 \frac{\text{m}}{\text{s}^2} \right) \right| = 484 \text{ N}$$

Load case: Deceleration

$$F_{x,3} = \left| 1000 \text{ N} + \left( 150 \text{ kg} + 0,15 \text{ kg} + 0,15 \text{ kg} + 1,85 \frac{\text{kg}}{\text{m}} \cdot 0,5 \text{ m} \right) \cdot \left( -4 \frac{\text{m}}{\text{s}^2} + \sin(-90^\circ) \cdot 9,81 \frac{\text{m}}{\text{s}^2} \right) \right| = 1088 \text{ N}$$

**Thrust rod retracting: Mass is moved upwards**

Load case: Acceleration

$$F_{x,4} = \left| -1000 \text{ N} + \left( 150 \text{ kg} + 0,15 \text{ kg} + 0,15 \text{ kg} + 1,85 \frac{\text{kg}}{\text{m}} \cdot 0,5 \text{ m} \right) \cdot \left( 4 \frac{\text{m}}{\text{s}^2} - \sin(-90^\circ) \cdot 9,81 \frac{\text{m}}{\text{s}^2} \right) \right| = 1088 \text{ N}$$

Load case: Constant Velocity

$$F_{x,5} = \left| -1000 \text{ N} + \left( 150 \text{ kg} + 0,15 \text{ kg} + 0,15 \text{ kg} + 1,85 \frac{\text{kg}}{\text{m}} \cdot 0,5 \text{ m} \right) \cdot \left( 0 \frac{\text{m}}{\text{s}^2} - \sin(-90^\circ) \cdot 9,81 \frac{\text{m}}{\text{s}^2} \right) \right| = 484 \text{ N}$$

Load case: Deceleration

$$F_{x,6} = \left| -1000 \text{ N} + \left( 150 \text{ kg} + 0,15 \text{ kg} + 0,15 \text{ kg} + 1,85 \frac{\text{kg}}{\text{m}} \cdot 0,5 \text{ m} \right) \cdot \left( -4 \frac{\text{m}}{\text{s}^2} - \sin(-90^\circ) \cdot 9,81 \frac{\text{m}}{\text{s}^2} \right) \right| = 121 \text{ N}$$

# Design Considerations – Permissible Axial Force

The risk of buckling is dependent on the stroke and mounting method. Use the charts below for the applicable mounting method and cylinder size to verify that the application's maximum axial force (calculations on page 42), is possible with the planned mounting method at the desired stroke. Please note that the retraction forces do not pose a buckling risk.

## Method 1

- ① Cylinders fixed with mounting flanges, foot mounting or mounting plates
- ② Thrust rod with axial guiding

## Method 2

- ① Cylinders fixed with mounting flanges, foot mounting or mounting plates
- ③ Thrust rod without axial guiding

## Method 3

- ④ Cylinders mounted via center trunnion or rear clevis
- ② Thrust rod with axial guiding

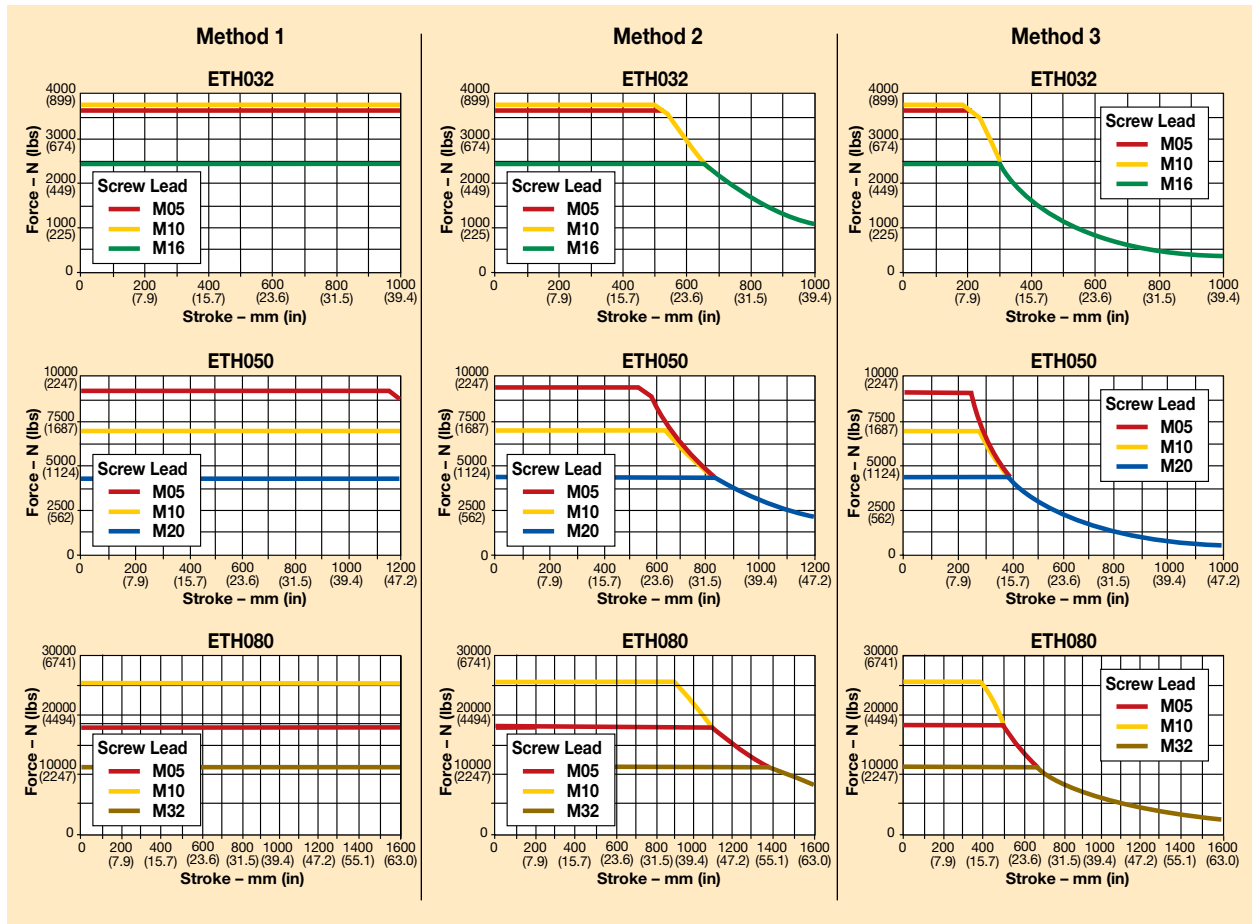
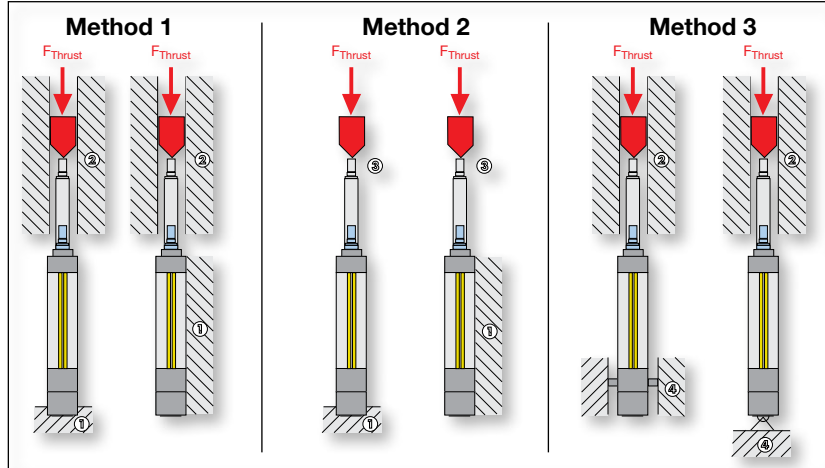

# Sizing/Selection

## Design Considerations — Service Life

### Nominal Service Life<sup>1</sup>

The nominal service life of the electric cylinder can be determined with the aid of the known forces.

The nominal service life is calculated as follows:

$$F_m = \sqrt[3]{\frac{1}{s_{ges}} (F_{x,1}^3 \cdot s_1 + F_{x,2}^3 \cdot s_2 + F_{x,3}^3 \cdot s_3 + \dots)}$$

(Index "j" for the individual segments of the application cycle. For example, the first segment would be  $F_{x,1}^3$  where j = 1, the second segment would be  $F_{x,2}^3$  where j = 2, etc.)

The forces calculated for each individual segment of the application cycle must be summarized into an equivalent axial force  $F_m$  (see "Calculating Required Axial Force", page 42).

### Nominal Service Life Prerequisites

- Bearing and screw temperature between 20°C and 40°C
- No impairment of the lubrication, for example by external particles
- Relubrication in accordance with the specifications
- The given values for thrust force, speed and acceleration must be adhered to at any rate
- No approaching the mechanical end stops (external or internal), no other abrupt loads, as the given maximum force of the cylinder may never be exceeded
- The given lateral forces applied to the cylinder rod must always be respected
- No high exploitation of several power features at a time (for example maximum speed or thrust force)
- No regulating oscillation at standstill

<sup>1</sup> Nominal service life is the service life reached by 90 % of a sufficient number of similar electric cylinders until the first signs of material fatigue occur.

### Actual Service Life

The actual service life can only be approximated due to a variety of different effects. The nominal service life L calculation does, for instance, not take insufficient lubrication, impacts and vibrations into consideration. These effects can however be estimated with the aid of the application factor  $f_w$ .

The actual service life is calculated as follows:

$$L_{fw} = \frac{L}{f_w^3}$$

If you need the service life as the number of possible cycles, just divide the service life in kilometers by twice the stroke traveled.

Standstill times are not taken into consideration when determining the equivalent axial force ( $F_m$ ), as  $s_j=0$ .

CAUTION: always consider the stroke as well as the return stroke.

### Formula Abbreviations

$F_m$	Equivalent axial force (N)
$F_x$ $F_j$	Resulting axial force in N (see formula 1 & 2, page 42)
$s_j$	Travel given a defined force $F_{x,a,j}$ (mm)
$s_{total}$	Total travel (mm)
$L$	Nominal service life in km (see Service Life graphs on page 45)
$L_{fw}$	Service life as a function of the application factor (km)
$f_w$	Application factor (see "Application Factor $F_w$ " table at right)

### Application Factor $f_w$ \*\*

Movement Cycle	Shocks/Vibrations			
	None	Light	Medium	Heavy
More than 2.5 screw rotations	1.0	1.2	1.4	1.7
1.0 to 2.5 screw rotations* (short stroke applications)	1.8	2.1	2.5	3.0

\* After max. 10000 movement cycles, a lubrication run must be performed (see lubrication run intervals table).

### \*\* Boundary Conditions for Application Factor $f_w$ :

- Externally guided electric cylinders
- Accelerations <10 m/s<sup>2</sup>
- Application factor <1.5
- For other conditions, please contact Parker

### Lubrication Run Lengths for Short Stroke Applications

Run Length	ETH032			ETH050			ETH080		
	M05	M10	M16	M05	M10	M20	M05	M10	M32
mm	>45	>54	>58	>40	>46	>58	>47	>65	>95

# Design Considerations — Service Life

Values are based on following recommended lubrication intervals.

(See relubrication for details, page 46).

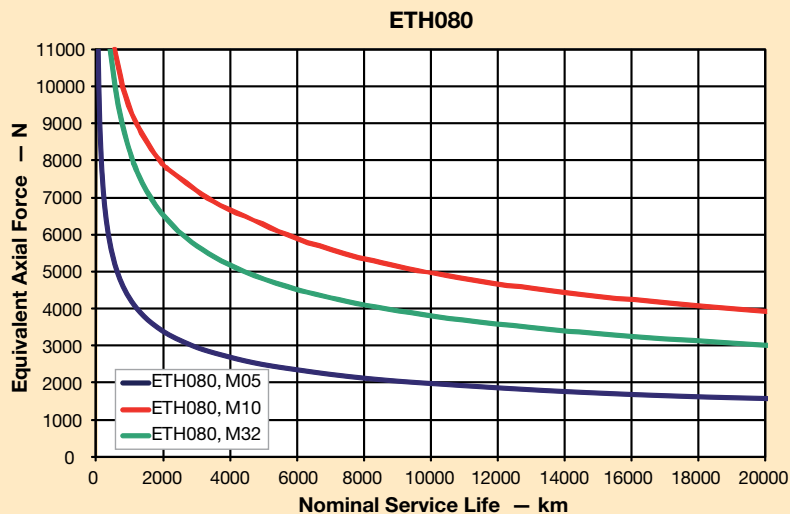
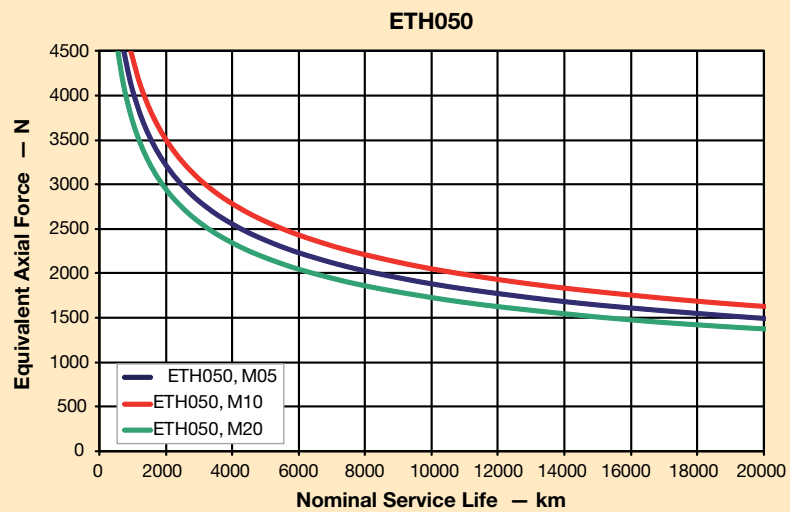
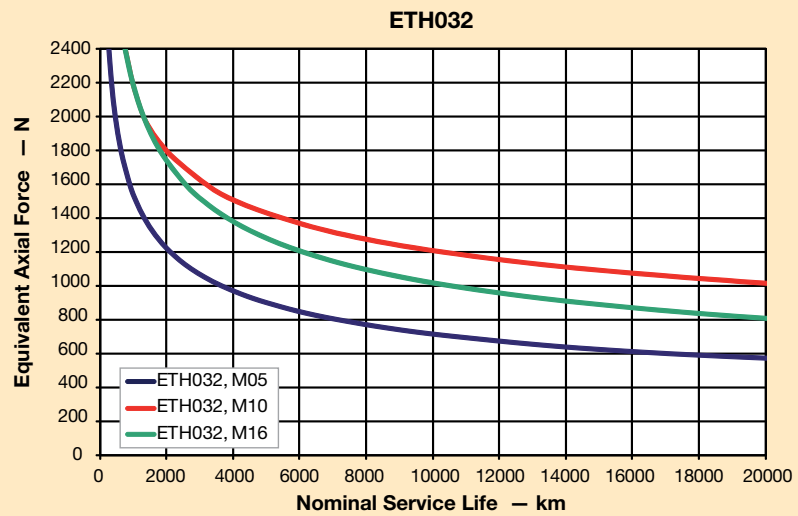

# Sizing/Selection

## Design Considerations — Relubrication

All frame sizes are designed with a range of lubrication port locations for maximum easy access. Contact factory for special needs not shown.

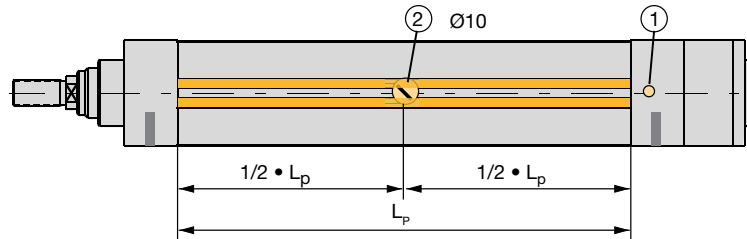

- ① Central lubrication (standard)
- ② Optional lubrication (possible on all 4 sides):  
L<sub>p</sub>: Length of profile

### Option 1: Integrated lubrication Port (standard)

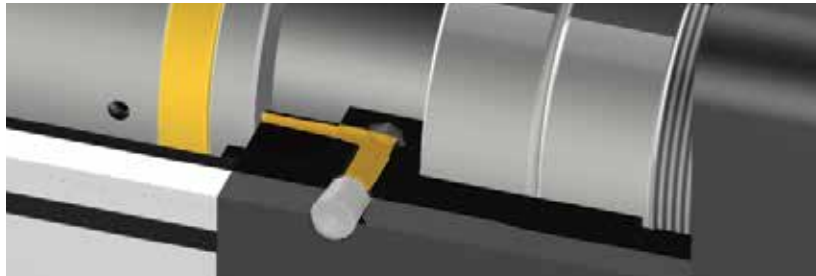

Relubrication is simple with the easy access port. Users simply perform a controlled retract of the cylinder approaching the endstop under slow speed and grease the cylinder.

The standard easy access port is always at the 3 o'clock position.

### Option 2...5: Lubrication Hole (optional)

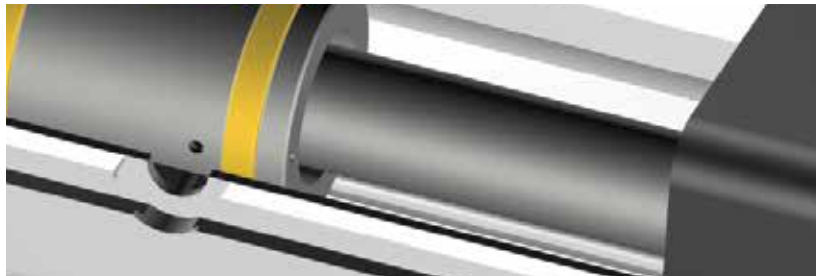

If a space constraint does not allow easy access to the standard lubrication port, other options in the part number configuration allow for a port at the center of the extrusion.

Free access to this bore even after integration of the cylinder into a system can be ensured by choosing the corresponding profile orientation (see order code page 48). The bore is located exactly in the middle of the aluminum profile.

### Lubrication Intervals\*

Lubrication intervals depend on the operating conditions (nominal size, pitch, speed, acceleration, loads, etc.) and the ambient conditions (e.g. temperature). Ambient influences such as high loads, impacts and vibrations shorten the lubrication intervals.

Under normal operating conditions, the given lubrication

intervals apply. If the total travel per year is shorter than the given intervals, the cylinder must be relubricated at least once per year. In the event of small loads and if the application is impact and vibration free, the lubrication intervals can be extended.

The lubricant used is Klüber and is available worldwide.

### Normal Operating Conditions:

- Medium screw velocity 2000 rpm
- Operating factor  $f_w=1.0$
- No impacts and vibrations

ETH032			ETH050			ETH080		
M05	M10	M16	M05	M10	M20	M05	M10	M32
300 km	600 km	960 km	300 km	600 km	1200 km	300 km	600 km	1500 km

# Design Considerations — Motor and Gearhead Selection

## Drive Torque Calculation

The torques to be produced by the motor result from the acceleration, the load and the friction torque. The drive torques must be calculated for all segments of the application cycle (represented by index “j”). Index “j” for the individual segments of the application cycle.

Calculation of the **acceleration torque** with respect to the rotary moments of inertia:

$$M_{B,j} = \left( J_{i/p,0} + J_{i/p,Hub} \cdot Hub \right) \cdot \frac{1}{\eta_{ETH}} \cdot \left( \frac{1}{i_G^2 \cdot \eta_G} + J_G + J_M \right) \cdot 10^{-3} \cdot \frac{6,28 \cdot a_{K,j}}{P_h}$$

$\frac{1}{i_G^2 \cdot \eta_G}$   
 (use only with gearhead)

The acceleration forces due to the translatory moved masses are taken into consideration in the calculation of the axial forces on page 42.

The **load torques** result from the occurring axial forces:

$$M_{L,j} = \frac{F_{x,a/e,j}}{\text{Thrust force factor}} \cdot \frac{1}{i_G \cdot \eta_G}$$

$\frac{1}{i_G \cdot \eta_G}$   
 (use only with gearhead)

The motor must therefore generate the following **drive torques**:

$$M_{M,j} = M_{B,j} + M_{L,j}$$

The peak torque of the motor must exceed the maximum occurring drive torque.

The **effective torque** can be deduced from the drive torques for all segments of the application cycle:

$$M_{eff} = \sqrt[2]{\frac{1}{t_{ges}} \cdot (M_{M1}^2 \cdot t_1 + M_{M2}^2 \cdot t_2 + \dots)}$$

The nominal torque of the motor must exceed the calculated effective torque. Refer to the Motor Mounting Configuration charts (pages 10-17), to verify that the motor is mechanically compatible to the corresponding electric cylinder.

## Formula Abbreviations



<b>M<sub>B,j</sub></b>	Variable acceleration torque in Nm
<b>J<sub>i/p,0</sub></b>	Red. rot. mass moment of inertia at zero stroke for inline/parallel motor configuration in kgmm <sup>2</sup> (see page 6)
<b>J<sub>i/p, stroke</sub></b>	Red. rot. mass moment of inertia per mm of stroke for inline/parallel motor configuration in kgmm <sup>2</sup> (see page 6)
<b>Stroke</b>	Selected stroke in mm
<b>η<sub>ETH</sub></b>	Efficiency of the electric cylinder (0.9 – inline drive configuration; 0.81 – parallel motor)
<b>i<sub>G</sub></b>	Gearhead ratio
<b>η<sub>G</sub></b>	Efficiency of the gearhead (see gearhead manufacturer specifications)
<b>J<sub>M</sub></b>	Motor mass moment of inertia in kgmm <sup>2</sup> (see motor manufacturer specifications)
<b>J<sub>G</sub></b>	Gearhead mass moment of inertia in kgmm <sup>2</sup> (see gearhead manufacturer specifications)
<b>a<sub>K,j</sub></b>	Acceleration at the cylinder rod in m/s <sup>2</sup>
<b>P<sub>h</sub></b>	Screw pitch in mm
<b>M<sub>L,j</sub></b>	Load torque in Nm
<b>F<sub>x,a/e,j</sub></b>	Loads in x direction in N (see page 42)
<b>M<sub>M,j</sub></b>	Drive torque in Nm
<b>M<sub>eff</sub></b>	Effective value — motor in Nm
<b>t<sub>total</sub></b>	Total cycle time in s
<b>t<sub>j</sub></b>	Amount of time in the cycle in s

# Ordering Information

Fill in an order code from each of the numbered fields to create a complete ETH model order code. Refer to the pages listed for further details.

	①	②	③	④	⑤	⑥	⑦	⑧	⑨	⑩		
<b>Order Example:</b>	ETH	032	M05	A	2	XPC	B	C	N	0200	C	B

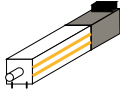
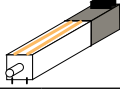
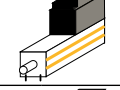
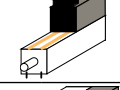
- ① **Series**  
ETH
- ② **Frame Size**  
(see “Performance by Cylinder Size and Screw Lead” chart and graphs, pages 6-9)
- |            |                     |
|------------|---------------------|
| <b>032</b> | ISO32 cylinder size |
| <b>050</b> | ISO50 cylinder size |
| <b>080</b> | ISO80 cylinder size |
- ③ **Drive Screw**  
(see “Performance by Cylinder Size and Screw Lead” chart, page 6)
- |            |   |
|------------|---|
| <b>M05</b> | 5 mm metric ballscrew                     |
| <b>M10</b> | 10 mm metric ballscrew                    |
| <b>M16</b> | 16 mm metric ballscrew (size ETH032 only) |
| <b>M20</b> | 20 mm metric ballscrew (size ETH050 only) |
| <b>M32</b> | 32 mm metric ballscrew (size ETH080 only) |

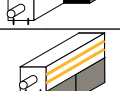
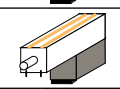
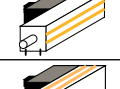
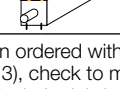
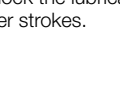
- ④ **Motor Mount/Cylinder Orientation**
- |          |   |   |
|----------|---|---|
| <b>A</b> |  | Inline w/groove for Initiator 3 & 9 o'clock               |
| <b>B</b> |  | Inline w/groove for Initiator 6 & 12 o'clock              |
| <b>C</b> |  | Parallel 12 o'clock w/groove for Initiator 3 & 9 o'clock  |
| <b>D</b> |  | Parallel 12 o'clock w/groove for Initiator 6 & 12 o'clock |
| <b>E</b> |  | Parallel 3 o'clock w/groove for Initiator 3 & 9 o'clock*  |
| <b>F</b> |  | Parallel 3 o'clock w/groove for Initiator 6 & 12 o'clock* |
| <b>G</b> |  | Parallel 6 o'clock w/groove for Initiator 3 & 9 o'clock   |
| <b>H</b> |  | Parallel 6 o'clock / groove for Initiator 6 & 12 o'clock  |
| <b>J</b> |  | Parallel 9 o'clock / groove for Initiator 3 & 9 o'clock   |
| <b>K</b> |  | Parallel 9 o'clock w/groove for Initiator 6 & 12 o'clock  |

\*When ordered with a lubrication bore option (item 5, order code 3), check to make sure the motor/gearbox length does not block the lubrication port option. This will be an issue for shorter strokes.

- ⑤ **Lubrication Bore Option**  
(see Relubrication Section for details, page 46)
- |          |  |
|----------|--|
| <b>1</b> | Integrated lubrication port*                       |
| <b>2</b> | Lubrication hole at center of extrusion 12 o'clock |
| <b>3</b> | Lubrication hole at center of extrusion 3 o'clock  |
| <b>4</b> | Lubrication hole at center of extrusion 6 o'clock  |
| <b>5</b> | Lubrication hole at center of extrusion 9 o'clock  |

\* Not available with Motor Mount/Cylinder Orientation with 3 o'clock orientation (order codes E and F)

- ⑥ **Motor Mounting Configurations**  
Motor-specific mounting configurations are categorized into four primary groups:  
“XP”: With Parker Xpress motor systems (listed below)  
“K”: Flange & coupling kits for other Parker motor  
“P”: Flange & coupling kits for Parker Gearheads  
“N”: Kits for Non standard motors

(Refer to pages 10-17 for appropriate order codes and mounting specifications for available inline and parallel motor mounting configurations)









		ETH032	ETH050	ETH080
<b>Parker Xpress Motor Systems</b>				
<b>XPC</b>	BE233FJ-KPSN	•	•	
<b>XPD</b>	BE233FJ-KPSB	•	•	
<b>XPG</b>	BE344LJ-KPSN	•	•	•
<b>XPH</b>	BE344LJ-KPSB	•	•	•
<b>XPL</b>	MPP1003D1E-KPSN		•	•
<b>XPM</b>	MPP1003D1E-KPSB		•	•
<b>XPN</b>	MPP1003D1E-KPSN *		•	•
<b>XPP</b>	MPP1003D1E-KPSB *		•	•
<b>XPQ</b>	MPP1003R1E-KPSN		•	•
<b>XPR</b>	MPP1003R1E-KPSB		•	•
<b>XPS</b>	MPP1003R1E-KPSN *		•	•
<b>XPT</b>	MPP1003R1E-KPSB *		•	•
<b>XPU</b>	MPP1154B1E-KPSN			•
<b>XPV</b>	MPP1154B1E-KPSB			•
<b>XPW</b>	MPP1154B1E-KPSN **			•
<b>XPX</b>	MPP1154B1E-KPSB **			•
<b>XPY</b>	MPP1154P1E-KPSN			•
<b>XPZ</b>	MPP1154P1E-KPSB			•
<b>XP1</b>	MPP1154P1E-KPSN **			•
<b>XP2</b>	MPP1154P1E-KPSB **			•

\* With PV34FE-003 gearhead on all inline and parallel sizes except size ETH080 parallel which comes with PV90FB-003

\*\* With PV115FB-003 gearhead

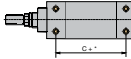

**7 Cylinder Mounting Options**  
(see pages 18-21 for details)

<b>B</b>		Foot mount
<b>C</b>		Rear clevis
<b>D</b>		Center trunnion
<b>E</b>		Rear eye
<b>F</b>		Bottom tapped (standard)
<b>G</b>		Side flange mount
<b>H</b>		Rear flange plate
<b>J</b>		Front flange plate
<b>N</b>		Front and rear flange plates (combining H and J options)

**8 Rod End Mounting Options**  
(see pages 22-25 for details)

<b>C</b>		Clevis
<b>F</b>		Female thread
<b>M</b>		Male thread
<b>S</b>		Spherical rod end
<b>L</b>		Alignment coupler
<b>R</b>		Linear guide module

**9 Stroke**  
For fastest delivery please choose a standard stroke length from the chart below. (See page 40 “Stroke, Usable Stroke and Safety Travel” to calculate appropriate stroke length.)

**Custom Lengths**

	ETH032	ETH050	ETH080
<b>XXXX</b>	50 – 1000	50 – 1200	50 – 1600
	(Customized length in 1 mm increments)		

**Standard Lengths**

	ETH032	ETH050	ETH080
<b>0050</b>	•	•	
<b>0100</b>	•	•	•
<b>0150</b>	•	•	•
<b>0200</b>	•	•	•
<b>0300</b>	•	•	•
<b>0400</b>	•	•	•
<b>0600</b>	•	•	•
<b>0900</b>		•	•
<b>1000</b>	•		
<b>1200</b>		•	•
<b>1600</b>			•

**10 IP Rating**

<b>A</b>	IP54 with galvanized steel hardware
<b>B</b>	IP54 with stainless steel hardware
<b>C</b>	IP65 epoxy coated cylinder

# Offer of Sale

The items described in this document and other documents or descriptions provided by Parker, its subsidiaries and its authorized distributors are hereby offered for sale at prices to be established by Parker Hannifin Corporation, its subsidiaries and its authorized distributors. This offer and its acceptance by any customer ("Buyer") shall be governed by all of the following Terms and Conditions. Buyer's order for any such item, when communicated to Parker, its subsidiary or an authorized distributor ("Seller") verbally or in writing, shall constitute acceptance of this offer.

1. Terms and Conditions of Sale: All descriptions, quotations, proposals, offers, acknowledgments, acceptances and sales of Seller's products are subject to and shall be governed exclusively by the terms and conditions stated herein. Buyer's acceptance of any offer to sell is limited to these terms and conditions. Any terms or conditions in addition to, or inconsistent with those stated herein, proposed by Buyer in any acceptance of an offer by Seller, are hereby objected to. No such additional, different or inconsistent terms and conditions shall become part of the contract between, Buyer and Seller unless expressly accepted in writing by Seller. Seller's acceptance of any offer to purchase by Buyer is expressly conditional upon Buyer's assent to all the terms and conditions stated herein, including any terms in addition to, or inconsistent with those contained in Buyer's offer. Acceptance of Seller's products shall in all events constitute such assent.

2. Payment: Payment shall be made by Buyer net 30 days from the date of delivery of the items purchased hereunder. Amounts not timely paid shall bear interest at the maximum rate permitted by law for each month or portion thereof that the Buyer is late in making payment. Any claims by Buyer for omissions or shortages in a shipment shall be waived unless Seller receives notice thereof within 30 days after Buyer's receipt of the shipment.

3. Delivery: Unless otherwise provided on the face hereof, delivery shall be made F.O.B. Seller's plant. Regardless of the method of delivery, however, risk of loss shall pass to Buyer upon Seller's delivery to a carrier. Any delivery dates shown are approximate only and Seller shall have no liability for any delays in delivery.

4. Warranty: Seller warrants that the items sold hereunder shall be free from defects in material or workmanship for a period of 12 months from date of shipment from Parker. THIS WARRANTY COMPRISES THE SOLE AND ENTIRE WARRANTY PERTAINING TO ITEMS PROVIDED HEREUNDER. SELLER MAKES NO OTHER WARRANTY, GUARANTEE, OR REPRESENTATION OF ANY KIND WHATSOEVER. ALL OTHER WARRANTIES, INCLUDING BUT NOT LIMITED TO, MERCHANTABILITY AND FITNESS FOR PURPOSE, WHETHER EXPRESS, IMPLIED, OR ARISING BY OPERATION OF LAW, TRADE USAGE, OR COURSE OF DEALING ARE HEREBY DISCLAIMED. NOTWITHSTANDING THE FOREGOING, THERE ARE NO WARRANTIES WHATSOEVER ON ITEMS BUILT OR ACQUIRED WHOLLY OR PARTIALLY, TO BUYER'S DESIGNS OR SPECIFICATIONS.

5. Limitation of Remedy: SELLER'S LIABILITY ARISING FROM OR IN ANY WAY CONNECTED WITH THE ITEMS SOLD OR THIS CONTRACT SHALL BE LIMITED EXCLUSIVELY TO REPAIR OR REPLACEMENT OF THE ITEMS SOLD OR REFUND OF THE PURCHASE PRICE PAID BY BUYER, AT SELLER'S SOLE OPTION. IN NO EVENT SHALL SELLER BE LIABLE FOR ANY INCIDENTAL, CONSEQUENTIAL OR SPECIAL DAMAGES OF ANY KIND OR NATURE WHATSOEVER, INCLUDING BUT NOT LIMITED TO LOST PROFITS ARISING FROM OR IN ANY WAY CONNECTED WITH THIS AGREEMENT OR ITEMS SOLD HEREUNDER, WHETHER ALLEGED TO ARISE FROM BREACH OF CONTRACT, EXPRESS OR IMPLIED WARRANTY, OR IN TORT, INCLUDING WITHOUT LIMITATION, NEGLIGENCE, FAILURE TO WARN OR STRICT LIABILITY.

6. Changes, Reschedules and Cancellations: Buyers may request to modify the designs or specifications for the items sold hereunder as well as the quantities and delivery dates thereof, or may request to cancel all or part of this order, however, no such requested modification or cancellation shall become part of the contract between Buyer and Seller unless accepted by Seller in a written amendment to this Agreement. Acceptance of any such requested modification or cancellation shall be at Seller's discretion, and shall be upon such terms and conditions as Seller may require.

7. Special Tooling: A tooling charge may be imposed for any special tooling, including without limitation, dies, fixtures, molds and patterns, acquired to manufacture items sold pursuant to this contract. Such special tooling shall be and remain Seller's property notwithstanding payment of any charges by Buyer. In no event will Buyer acquire any interest in apparatus belonging to Seller which is utilized in the manufacture of the items sold hereunder, even if such apparatus has been specially converted or adapted for such manufacture

and not withstanding any charges paid by Buyer. Unless otherwise agreed, Seller shall have the right to alter, discard or otherwise dispose of any special tooling or other property in its sole discretion at any time.

8. Buyer's Property: Any designs, tools, patterns, materials, drawings confidential information or equipment furnished by Buyer, or any other items which become Buyer's property, may be considered obsolete and may be destroyed by Seller after two (2) consecutive years have elapsed without Buyer placing an order for the items which are manufactured using such property. Seller shall not be responsible for any loss or damage to such property while it is in Seller's possession or control.

9. Taxes: Unless otherwise indicated on the face hereof, all prices and charges are exclusive of excise, sales, use, property, occupational or like taxes which may be imposed by any taxing authority upon the manufacture, sale or delivery of the items sold hereunder. If any such taxes must be paid by Seller or if Seller is liable for the collection of such tax, the amount thereof shall be in addition to the amounts for the items sold. Buyer agrees to pay all such taxes or to reimburse Seller therefore upon receipt of its invoice. If Buyer claims exemption from any sales, use or other tax imposed by any taxing authority, Buyer shall save Seller harmless from and against any such tax, together with any interest or penalties thereon which may be assessed if the items are held to be taxable.

10. Indemnity For Infringement of Intellectual Property Rights: Seller shall have no liability for infringement of any patents, trademarks, copyrights, trade dress, trade secrets or similar rights except as provided in this Part 10. Seller will defend and indemnify Buyer against allegations of infringement of U.S. patents, U.S. trademarks, copyrights, trade dress and trade secrets (hereinafter "Intellectual Property Rights"). Seller will defend at its expense and will pay the cost of any settlement or damages awarded in an action brought against Buyer based on an allegation that an item sold pursuant to this contract infringes the Intellectual Property Rights of a third party. Seller's obligation to defend and indemnify Buyer is contingent on Buyer notifying Seller within ten (10) days after Buyer becomes aware of such allegations of infringement, and Seller having sole control over the defense of any allegations or actions including all negotiations for settlement or compromise. If an item sold hereunder is subject to a claim that it infringes the Intellectual Property Rights of a third party, Seller may, at its sole expense and option, procure for Buyer the right to continue using said item, replace or modify said item so as to make it non infringing, or offer to accept return of said item and return the purchase price less a reasonable allowance for depreciation. Notwithstanding the foregoing, Seller shall have no liability for claims of infringement based on information provided by Buyer, or directed to items delivered hereunder for which the designs are specified in whole or part by Buyer, or infringements resulting from the modification, combination or use in a system of any item sold hereunder. The foregoing provisions of this Part 10 shall constitute Seller's sole and exclusive liability and Buyer's sole and exclusive remedy for infringement of Intellectual Property Right. If a claim is based on information provided by Buyer or if the design for an item delivered hereunder is specified in whole or in part by Buyer, Buyer shall defend and indemnify Seller for all costs, expenses or judgments resulting from any claim that such item infringes any patent, trademark, copyright, trade dress, trade secret or any similar right.

11. Force Majeure: Seller does not assume the risk of and shall not be liable for delay or failure to perform any of Seller's obligations by reason of circumstances beyond the reasonable control of Seller (hereinafter "Events of Force Majeure"). Events of Force Majeure shall include without limitation, accidents, acts of God, strikes or labor disputes, acts, laws, rules or regulations of any government or government agency, fires, floods, delays or failures in delivery of carriers or suppliers, shortages of materials and any other cause beyond Seller's control.

12. Entire Agreement/Governing Law: The terms and conditions set forth herein, together with any amendments, modifications and any different terms or conditions expressly accepted by Seller in writing, shall constitute the entire Agreement concerning the items sold, and there are no oral or other representations or agreements which pertain thereto. This Agreement shall be governed in all respects by the law of the State of Ohio. No actions arising out of the sale of the items sold hereunder of this Agreement may be brought by either party more than two (2) years after the cause of action accrues.

## WARNING

FAILURE OR IMPROPER SELECTION OR IMPROPER USE OF THE PRODUCTS AND/OR SYSTEMS DESCRIBED HEREIN OR RELATED ITEMS CAN CAUSE DEATH, PERSONAL INJURY AND PROPERTY DAMAGE.

This document and other information from Parker Hannifin Corporation, its subsidiaries and authorized distributors provide product and/or system options for further investigation by users having technical expertise. It is important that you analyze all aspects of your application and review the information concerning the product or system in the current product catalog. Due to the variety of operating conditions and applications for these products or systems, the user, through its own analysis and testing, is solely responsible for making the final selection of the products and systems and assuring that all performance, safety and warning requirements of the application are met.

The products described herein, including without limitation, product features, specifications, designs, availability and pricing, are subject to change by Parker Hannifin Corporation and its subsidiaries at any time without notice.

# Extensive Automation Solutions

## HMI and Controllers



Superior integration and support for machine control as well as HMI hardware and software.

[www.parkermotion.com/em/hmicont](http://www.parkermotion.com/em/hmicont)

## Electric Actuators



Screw, belt-driven, and linear motor actuators for the complete range of industrial applications, offering precise motion and flexibility.

[www.parkermotion.com/em/linear](http://www.parkermotion.com/em/linear)

## Motors and Drives



Parker's family of innovative servo/stepper motors and drives continues to expand to meet the challenges of new technologies.

[www.parkermotion.com/em/motordrive](http://www.parkermotion.com/em/motordrive)

## Linear Actuator



Aluminum and steel pneumatic cylinders, guided cylinders, rodless cylinders, and short stroke thrusters from the industry leader.

[www.parkermotion.com/pneu/linear](http://www.parkermotion.com/pneu/linear)

## Rotary Actuators



Industry leader in the design and manufacture of pneumatic rack and pinion, and vane-style rotary actuators.

[www.parker.com/pneu/rotary](http://www.parker.com/pneu/rotary)

## Vacuum Products and Sensors



Vacuum solutions include a broad range of generators (integrated/inline), cups, and pressure sensors.

[www.parker.com/pneu/vacsen](http://www.parker.com/pneu/vacsen)

## Grippers



Parallel, angular, and three jaw grippers are available in over 1,000 configurations.

[www.parker.com/pneu/gripper](http://www.parker.com/pneu/gripper)

## Airline Accessories



Airline accessories include silencers, flow controls, and mufflers to round out Parker's pneumatic solution.

[www.parker.com/pneu/access](http://www.parker.com/pneu/access)

## Air Control Valves



Valve technology that meets the most demanding requirements in any industrial application.

[www.parker.com/pneu/valve](http://www.parker.com/pneu/valve)

## Air Preparation



Parker, the industry leader in air preparation, offers a complete line of products to ensure clean, dry, oil-free air.

[www.parker.com/pneu/airprep](http://www.parker.com/pneu/airprep)

## Connectors and Tubing



The most complete line of fluid connectors worldwide will meet virtually any automation application.

[www.parker.com/pneu/fc](http://www.parker.com/pneu/fc)

## Structural Automation



More than 150 metric and inch profiles, integral motion components, and accessories for unlimited and flexible configurations. Pre-machined kits or complete assemblies.

[www.parker.com/ips](http://www.parker.com/ips)

# EM Sales Offices

## Australia

**Parker Hannifin (Australia) Pty Ltd.**  
9 Carrington Road  
Castle Hill NSW 2154  
Australia  
Tel: +61 (0) 2 9634-7777  
Fax: +61 (0) 2 9634 3749

## Brazil

**Parker Hannifin Ind. Com Ltda.**  
Av. Lucas Nogueira Garcez 2181  
Esperança  
12325-900 Jacareí, SP  
Tel: 12 3954 5100  
Fax: 12 3954 5262  
Email: automation.brazil@parker.com

## Canada

**Parker Hannifin (Canada) Inc.**  
160 Chisholm Dr  
Milton, Ontario L9T 3G9  
Tel: 905-693-3000  
Fax: 905-876-1958  
Email: miltoncustservice@parker.com

## China

**Parker Hannifin Motion & Control**  
(Shanghai) Co., Ltd  
280 Yunqiao Rd. Jin Qiao Export  
Processing Zone  
Shanghai 201206, China  
Tel: (86-21) 50312525  
Fax: (86-21) 64459717

## France

**Parker SSD Parvex**  
8 avenue du Lac  
B.P. 249  
F-21007 Dijon Cedex  
Tel: +33 (0) 3 80 42 41 40  
Fax: +33 (0) 3 80 42 41 23

## Germany

**Electricmechanical Europe**  
**Parker Hannifin GmbH & Co KG**  
Robert-Bosch-Strasse 22  
D-77656 Offenburg  
Germany  
Tel: +49 (0) 781 509 0  
Fax: +49 (0) 781 509 98176

## India

**Parker Hannifin India Pvt. Ltd**  
**Automation Group-SSD Drives Div.**  
133 & 151 Developed Plots Estate  
Perungudi, Chennai 600 096  
Tel: 044-4391-0799  
Fax: 044-4391-0700

## Italy

**Parker Hannifin SpA**  
Via Gounod 1  
20092 Cinsello Balsamo  
Milano, Italy  
Tel: +39 02 361081  
Fax: +39 02 36108400

## Korea

Parker Hannifin Korea  
9th Floor KAMCO Yangjae Tower  
949-3 Dogok 1-dong Gangnam-gu  
Seoul 135-860, Korea  
Tel: 82-2-559-0454  
Fax: 82-2-556-8187

## Mexico

**Parker Hannifin de Mexico**  
Eje uno Norte No.100  
Parque Industrial Toluca 2000  
Toluca, CP 50100 México  
Tel: 52-722-275-4200  
Fax: 52-722-279-0316

## Singapore

**Parker Hannifin Singapore Pte Ltd**  
11, Fourth Chin Bee Road  
Singapore 619702  
Tel: (65) 6887 6300  
Fax: (65) 6265 5125/6261 4929

## Taiwan

**Parker Hannifin Taiwan Co., Ltd**  
No. 40, Wuchiuan 3rd Road  
Wuku Industrial Park  
Taipei County, Taiwan 248  
ROC  
Tel: 886 2 2298 8987  
Fax: 886 2 2298 8982

## Thailand

**Parker Hannifin (Thailand) Co., Ltd.**  
1265 Rama 9 Road  
Suanluang, Bangkok 10250  
Thailand  
Tel: (66) 2 186 7000  
Fax: (66) 2 374 1645

## UK

**Parker Hannifin Ltd.**  
Tachbrook Park Drive  
Tachbrook Park  
Warwick CV34 6TU  
Tel: +44 (0) 1926 317970  
Fax: +44 (0) 1926 317980

## USA

**Parker Hannifin Electricmechanical**  
**Automation Division Main Office/**  
**Compumotor/CTC**  
5500 Business Park Drive  
Rohnert Park, CA 94928 USA  
Tel: 707-584-7558  
800-358-9070  
Fax: 707-584-8015  
Email: emn\_support@parker.com

**Parker Hannifin Electricmechanical**  
**Automation Division/Daedal**  
1140 Sandy Hill Road  
Irwin, PA 15642  
Tel: 724-861-8200  
800-245-6903  
Fax: 724-861-3330  
Email: ddldcat@parker.com

